

# FLOW-SMS

## Surface Mount System for Mass Flow / Pressure Meters and Controllers

### > Introduction

Bronkhorst High-Tech B.V., the European market leader in Thermal Mass Flow Meters/Controllers and Electronic Pressure Controllers, has many years of experience in designing and manufacturing precise and reliable measurement and control devices. With a wide range of instruments, Bronkhorst High-Tech offers innovative solutions for many different applications in a variety of different markets.

### > FLOW-SMS series, compact assemblies of functional modules

Bronkhorst High-Tech developed the FLOW-SMS series for customers who are looking for process gas panels with optimal space efficiency. On a compact, lightweight but still rugged mounting rail system one or more mass flow or pressure sensor modules can be combined with control valves, shut-off valves, mixing chambers, filters or any other functional module as per customer's request. The modular concept of the FLOW-SMS system offers great flexibility for the end-user with respect to modifications and serviceability. The functional modules are 'top-mount', so they can easily be exchanged without removing the total assembly.

The ranges for the flow meters and controllers can be selected between approx. 5 ml<sub>n</sub>/min up to 50 l<sub>n</sub>/min or even higher. In case a pressure meter or controller is included, the pressure range can be chosen between 0-100 mbar and 0-10 bar absolute or gauge. Depending on the application the customer may prefer a system with compression type couplings, face seal fittings or flanges according to customers' specification. On request, the system will be assembled, tested, and packaged in a cleanroom.

### > Fields of application

The FLOW-SMS Series has great potential in many different markets, for instance in:

- ◆ Vacuum, plasma, sputter and coating processes
- ◆ Catalytical test benches
- ◆ Semiconductor and solar cell fabrication
- ◆ Burner control (welding)
- ◆ Biotechnological and chemical installations
- ◆ Food and beverage processes



### > FLOW-SMS features

- ◆ Compact assembly ensures space efficiency and minimized dead volume
- ◆ Economical solution, low cost of ownership
- ◆ Tubeless construction reduces potential leak points
- ◆ Service friendly; easily accessible from the top
- ◆ Great flexibility regarding system extension or modification
- ◆ Pre-tested "Plug and Work" units, reducing custom testing requirements

### > Digital features

- ◆ Analog or digital communication (RS232, DeviceNet™, PROFIBUS DP, Modbus, EtherCAT®, PROFINET, FLOW-BUS)
- ◆ Optional PROFIBUS Gateway offering cost-effectiveness at 3 or more channels
- ◆ Alarm and counter functions
- ◆ Control characteristics user-configurable
- ◆ Optional Multi Gas / Multi Range functionality
- ◆ Free software tools

# FUNCTIONAL MODULES

## > Mass flow meters / controllers

The mass flow sensor operates on a principle of heat transfer by sensing the temperature difference along a heated section of a capillary tube. Part of the total flow is forced through the capillary by means of a laminar flow element in the main stream generating a pressure difference. The design of the laminar flow device is such that flow conditions in both the capillary and laminar flow device are comparable, thereby resulting in proportional flow rates through the meter. The  $\Delta T$  sensed by the upstream and downstream temperature sensors on the capillary depends on the amount of heat absorbed by the gas flow.

The control valve used in the FLOW-SMS series is a standard, direct operated solenoid valve (normally opened or normally closed), operated through the PID-control function on the pc-board of the flow or pressure meter. The orifice diameter is optimised for the customer's specification.



## > Pressure meters / controllers

FLOW-SMS pressure meters/controllers range from 100 mbar up to 10 bar, measuring either absolute pressure or gauge pressure, with a very high accuracy and repeatability.

The instruments are equipped with a diaphragm based piezo-resistive sensor. Pressure controllers are available as forward controller (PS-600 series) and backward controller (PS-700 series). The flow going through the pressure controller depends on up and downstream pressures, orifice diameter of the valve and the density of the fluid.



## > Filter modules

To protect the instruments from particles it is possible to integrated filter modules in your FLOW-SMS system.

Pore sizes : 0,5 – 2 – 7 – 15 micron



## > Solenoid operated shut off valves

Solenoid-operated shut off valves are available in Normally Closed (NC) and Normally Opened (NO) configuration. A spring action opens or closes the valve instantly when it is either energized or de-energized. Solenoid shut off valves are applied to offer extra safety in case of system failure or to reduce the leak-by rates in the system.

Supply voltage : + 24Vdc  
 Power consumption : 3 Watt  
 Max.  $\Delta P$  : 3 bar dif.  
 Kv-max. : 0,065



## > Pneumatic operated shut off valves and 3/2 valves

Similar to the solenoid valves mentioned above, pneumatic operated shut off valves are available in Normally Closed (NC) and Normally Opened (NO) configuration. The 2/2-way shut off valves can be supplied with optional feedback sensor.

Actuation pressure : 3...9 barg (2/2-way shut off)  
 or 4...9 barg (3/2-way valve)  
 Kv-max. : 0,2 (2/2-way and NC 3/2-way),  
 0,085 (NO 3/2-way)



## > Toggle valves

These valves can be used for quick acting and positive on/off control.

Kv-max. : 0,09



## > Needle valves

Needle valves may be used in flow metering applications, e.g. when a constant, low flow rate must be maintained for some time.

Various Kv-ranges



# MANIFOLD COMPONENTS

The functional modules described on the previous page are mounted on a modular manifold assembly, consisting of support rails, base bodies, distribution and mixing chambers and adapter or blind plates.

## > Support rails

Each FLOW-SMS system is supported by two mounting rails, which also provide panel mounting capability for the total system. There are support rail sets for 3 up to 9 channels available.

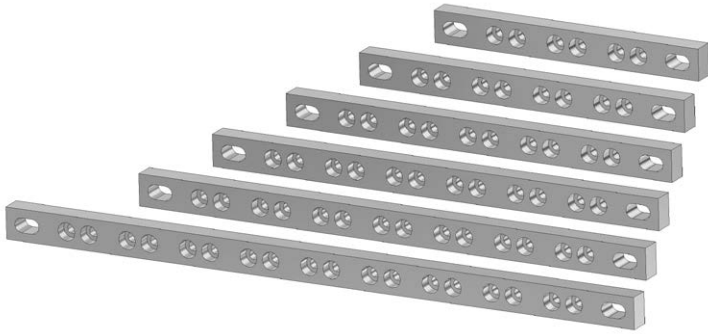

## > Distribution and mixing chambers

A distribution chamber at the front end of a FLOW-SMS system provides the ability to distribute one or more gases among a number of flow paths. At the downstream side, mixing chambers can be integrated to combine the outputs of various flow channels. Please note that the maximum flow capacity for distribution or mixing chambers is 50 l<sub>n</sub>/min air-equivalent (or 70 l<sub>n</sub>/min H<sub>2</sub>/He).

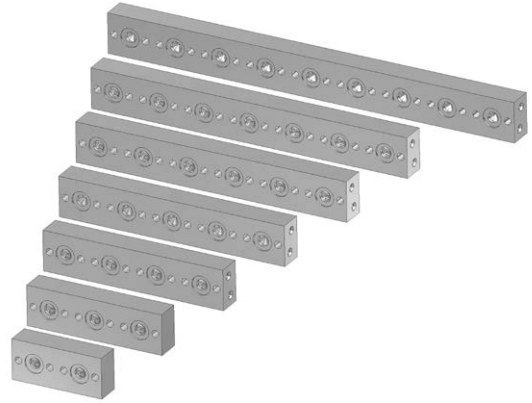

## > Base bodies

Two types of base bodies provide support for the functional modules. There is one size for meters/controllers and another for filter modules and valves.



## > Adapter plates and blind plates

The compression type (1/8" / 1/4" / 6 mm) or 1/4" face seal adapter plates are designed to bolt on to the inlets and outlets of base bodies and distribution/mixing chambers. Blind plates provide a cover for unused in- and outlets of distribution and mixing chambers.



## > Configuration software tool

Because of the infinite number of possible solutions, we recommend you to contact our nearest distributor to discuss your application. With the online FLOW-SMS configuration software Bronkhorst assists you designing your bespoke

FLOW-SMS system by arranging functional modules viz. flow or pressure meters/controllers, valves and filters in combination with mixing chambers, adapter plates, mounting rails, etc. (see below example).

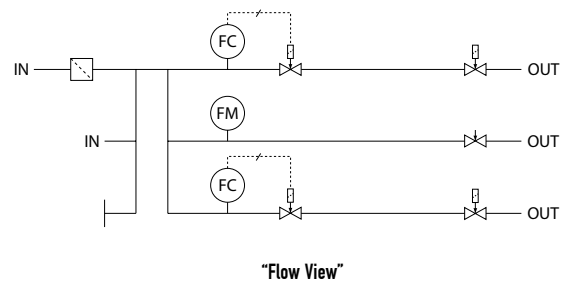
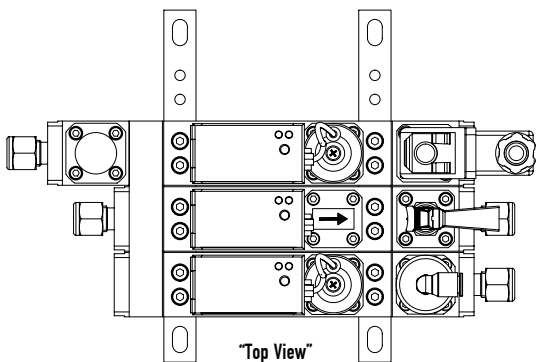

## > Technical specifications Mass Flow / Pressure Modules

### MASS FLOW measurement / control modules

Accuracy (incl. linearity) (based on actual calibration)	: standard: $\pm 0,5\%$ Rd plus $\pm 0,1\%$ FS; for ranges 3..5 ml <sub>v</sub> /min: $\pm 1\%$ FS
Turndown	: 1 : 50 (in digital mode up to 1 : 187,5)
Repeatability	: $< 0,2\%$ Rd
Settling time (controller)	: 1...2 seconds typical above 5% FS;
Control stability	: $< \pm 0,1\%$ FS (typical for 1 l <sub>v</sub> /min N <sub>2</sub> )
Max. operating pressure	: 10 bar gauge
Temperature sensitivity	: zero: $< 0,05\%$ FS/°C; span: $< 0,05\%$ Rd/°C
Pressure sensitivity	: 0,1% Rd/bar typical N <sub>2</sub> , 0,01% Rd/bar typical H <sub>2</sub>
Warm-up time	: 30 min. for optimum accuracy 2 min for accuracy $\pm 2\%$ FS

### PRESSURE measurement / control modules

Accuracy (incl. linearity)	: $\pm 0,5\%$ of full scale (FS)
Pressure rangeability	: Measurement: 1 : 50 (2...100%) Control (with flow range 1 : 50) PS-602CV 1 : 20, PS-702CV 1 : 5
Repeatability	: $< 0,1\%$ FS
Response time sensor	: $< 0,1$ second
Control stability	: $< \pm 0,1\%$ FS (typical for 1 l <sub>v</sub> /min N <sub>2</sub> at specified process volume)
Temperature sensitivity	: 0,1% FS/°C;

### General performance Mass Flow / Pressure modules

Operating temperature	: -10...+50°C
Leak integrity (outboard)	: tested $< 2 \times 10^{-9}$ mbar.l/s He
Leak-by through closed control valve:	$< 10^{-4}$ mbar.l/s He
Attitude sensitivity	: may be mounted in any position

### Mechanical parts

Material (wetted parts)	: stainless steel 316L or comparable
Process connections	: compression type or face seal couplings
Seals	: standard Viton® options: EPDM, FFKM (Kalrez)
Ingress protection (housing)	: IP40



Example of an 8-channel  
FLOW-SMS system with PROFIBUS Gateway

### Electrical properties

Power supply	: +15...24 Vdc
Power consumption	: meter: 70 mA; controller: max. 320 mA; add 50 mA for Profibus, if applicable
Analog output	: 0...5 (10) Vdc, min. load impedance $> 2$ k $\Omega$ ; 0 (4)...20 mA (sourcing), max. load impedance $< 375$ $\Omega$
Analog setpoint	: 0...5 (10) Vdc, min. load impedance $> 100$ k $\Omega$ ; 0 (4)...20 mA, load impedance $\sim 250$ $\Omega$
Digital communication	: standard: RS232 options: PROFIBUS DP, DeviceNet™, Modbus, EtherCAT®, PROFINET, FLOW-BUS
Electrical connection	
Analog/RS232	: 9-pin D-connector (male);
PROFIBUS DP	: bus: 9-pin D-connector (female); power: 9-pin D-connector (male);
DeviceNet™	: 5-pin M12-connector (male);
Modbus/EtherCAT®/FLOW-BUS/	: RJ45 modular jack
PROFINET	

#### Notes:

- Mass flow units ml<sub>v</sub>/min and l<sub>v</sub>/min refer to 0°C (32°F) and 1013 mbar (14.7 psi)
- For 3 or more PROFIBUS channels we advise to use our Gateway module
- Technical specifications subject to change without notice.
- For dimensional drawings see the downloads section at [www.bronkhorst.com](http://www.bronkhorst.com)

## > Models and ranges

### Mass Flow Meters (MFM); ranges based on N<sub>2</sub>

Model	min. flow	max. flow
FS-100C	0,06...3 ml <sub>v</sub> /min	0,18...9 ml <sub>v</sub> /min
FS-101C	0,16...8 ml <sub>v</sub> /min	0,2...10 l <sub>v</sub> /min
FS-102C	0,08...4 l <sub>v</sub> /min	1...50 l <sub>v</sub> /min

### Mass Flow Controllers (MFC)

Model	min. flow	max. flow
FS-200CV <sup>1)</sup>	0,06...3 ml <sub>v</sub> /min	0,18...9 ml <sub>v</sub> /min
FS-201CV <sup>1)</sup>	0,16...8 ml <sub>v</sub> /min	0,2...10 l <sub>v</sub> /min
FS-202CV <sup>1)</sup>	0,08...4 l <sub>v</sub> /min	1...50 l <sub>v</sub> /min

### Electronic Pressure Transducers (EPT)

Model	min. pressure	max. pressure
PS-502C	2...100 mbar <sup>2)</sup>	0,2...10 bar <sup>2)</sup>

### Electronic Pressure Controllers (EPC)

Model	min. pressure	max. pressure
PS-602CV <sup>1)</sup> (forward pressure control)	5...100 mbar <sup>2)</sup>	0,5...10 bar <sup>2)</sup>
PS-702CV <sup>1)</sup> (back pressure control)	20...100 mbar <sup>2)</sup>	2...10 bar <sup>2)</sup>

<sup>1)</sup> Kv-max =  $6,6 \times 10^{-2}$

<sup>2)</sup> Absolute or relative (gauge)