

# M50 - 2" PULSE METERS

The M50 is the largest capacity meter in the M Series range. It has the ability to handle a wide range of fluid viscosities with exceptional levels of repeatability and durability.



**M50AR-P-3**

## Product Benefits

- Compact size.
- Two independent pulse units which can be linked to allow doubling of the pulse output (or in-built spare if used as single).
- Has IP66/NEMA6 protection and flameproof certification.
- Low pressure drop allows for economical pump selection or gravity flow applications.
- Flexibility of installation options (e.g. can be mounted horizontally or vertically; no flow conditioning required).
- Meter construction enables fast and easy on-site servicing without removal from application.
- Meter accuracy is verified by a factory calibration check after which an individual metrology report is issued.
- Meter design minimises the number of wearable and replaceable parts and extends product life.
- Will handle particle sizes to 0.46mm/0.018".

**STANDARDS AUSTRALIA** 

MODEL	M50AR-P-X	M50SRP-X
METER TYPE	PULSE	PULSE
METER BODY MATERIAL	AA601 ALUMINIUM	316 STAINLESS STEEL
WETTED COMPONENTS:		
ROTOR MATERIAL	PPS	PPS
SHAFTS	316 STAINLESS STEEL	316 STAINLESS STEEL
O-RING	NBR (NITRILE)	NBR (NITRILE)
FLOW RATE RANGES (litres per minute/US gallons per minute)		
ABOVE 5 CPS	15 to 350 / 3.96 to 92.46	15 to 350 / 3.96 to 92.46
BELOW 5 CPS	30 to 300 / 7.93 to 79.25	30 to 300 / 7.93 to 79.25
ACCURACY- WITHIN (OF READING)	+/- 0.5%	+/- 0.5%
REPEATABILITY	0.03%	0.03%
MAXIMUM VISCOSITY (OF STANDARD MODEL)	1000 Centipoise	1000 Centipoise
MAXIMUM OPERATING PRESSURE	AS PER FLANGE RULE	AS PER FLANGE RULE
PULSER TYPE	HALL EFFECT OR REED SWITCH OR COMBINATION HE / RS	HALL EFFECT OR REED SWITCH OR COMBINATION HE / RS
PULSES PER LITRE/US GALLONS	6.68 / 25.29	6.68 / 25.29
MAX. OPERATING TEMPERATURE	80°C / 176°F	80°C / 176°F
RECOMMENDED MESH STRAINER SIZE	60 MESH	60 MESH

**Port Size** To order flowmeter you must replace 'X' with the relevant number. This number will determine the following specifications:

**Port Size:**

- 3 = 2" ANSI 150lb Flange
- 4 = 2" ANSI 150lb Flange
- 5 = 50mm DIN 16 Flange

**Electrical Conduit Connection:**

- 20mm (F)
- 1/2" NPT (F)
- 20mm (F)

**Calibrated and Display In:**

- Litres
- US Gallons
- Litres

PPS = Polyphenylene Sulfide Resins



# M50 - 2" PULSE METERS

# TYPE M50 - 2" PULSE METERS

## Weights

MODEL	M5OARP-3	M5OARP-4	M5OARP-5	M5OSRP-3	M5OSRP-4	M5OSRP-5
WEIGHT	10kg / 22lbs	10kg / 22lbs	10kg / 22lbs	23kg / 50.60lbs	23kg / 50.60lbs	23kg / 50.60lbs

## Options & Accessories

M50 - 2" METER	VITON O-RING	TEFLON O-RING	EPDM O-RING	HIGH TEMP ROTORS	HIGH VISCOSITY ROTORS	HALL EFFECT SENSOR	REED SWITCH	SOLVENT KIT	HASTALLOY C SHAFTS	PROTECTIVE BOOT	EXTENDED LIFE BATTERY	REMOTE MOUNTED LC DISPLAY	HEATING JACKET	4-20mA MODULE
M5OARP-X	O	O	O	O	O	O	S	X	X	X	X	A	A	A
M5OSRP-X	O	O	O	O	O	O	S	X	X	X	X	A	A	A

S = Standard

O = Optional

X = Not Available

A = Accessory

## Dimensions

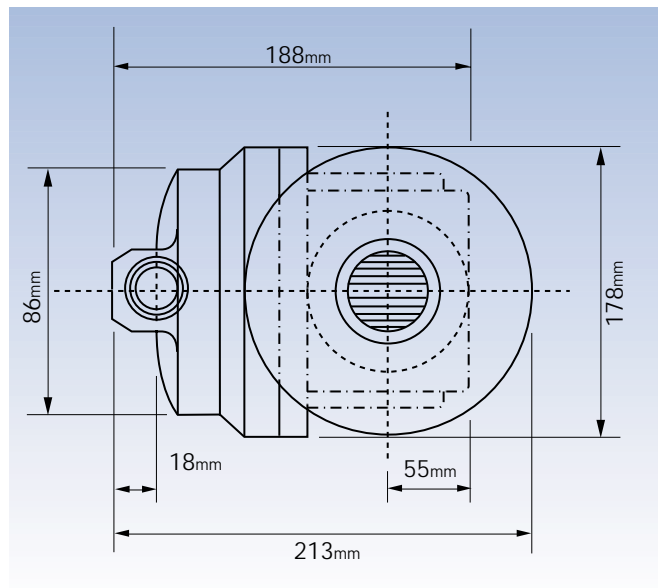
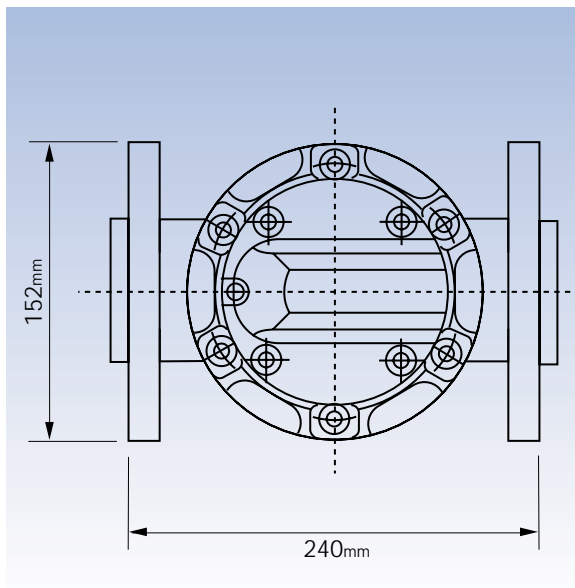

# M50 - 2" PULSE METERS WITH STANDARD LC DISPLAY

The M50 is the largest capacity meter in the M Series range. It has the ability to handle a wide range of fluid viscosities with exceptional levels of repeatability and durability



**M50ARG-3**

## Product Benefits

- Compact size.
- Flexibility of installation options (e.g. can be mounted horizontally or vertically; no flow conditioning required).
- Built in auxiliary pulse output available.
- Low pressure drop allows for economical pump selection or gravity flow applications.
- Meter construction enables fast and easy on-site servicing without removal from application.
- Meter accuracy is verified by a factory calibration check after which an individual metrology report is issued.
- Meter design minimises the number of wearable and replaceable parts and extends product life.
- LC Display meets European CE directive.
- Has IP54/NEMA13 protection.

MODEL	M50ARG-X	M50SRG-X
METER TYPE	PULSE WITH STANDARD LC DISPLAY	PULSE WITH STANDARD LC DISPLAY
METER BODY MATERIAL	AA601 ALUMINIUM	316 STAINLESS STEEL
WETTED COMPONENTS:		
ROTOR MATERIAL	PPS	PPS
SHAFTS	316 STAINLESS STEEL	316 STAINLESS STEEL
O-RING	NBR (NITRILE)	NBR (NITRILE)
FLOW RATE RANGES (litres per minute/US gallons per minute)		
ABOVE 5 CPS	15 to 350 / 3.96 to 92.46	15 to 350 / 3.96 to 92.46
BELOW 5 CPS	30 to 300 / 7.93 to 79.25	30 to 300 / 7.93 to 79.25
ACCURACY- WITHIN (OF READING)	+/- 0.5%	+/- 0.5%
REPEATABILITY	0.03%	0.03%
MAXIMUM VISCOSITY (OF STANDARD MODEL)	1000 Centipoise	1000 Centipoise
MAXIMUM OPERATING PRESSURE	AS PER FLANGE RULE	AS PER FLANGE RULE
PULSER TYPE	REED SWITCH OR COMBINATION HE / RS	REED SWITCH OR OR COMBINATION HE / RS
PULSES PER LITRE/US GALLONS	6.68 / 25.29	6.68 / 25.29
MAX. OPERATING TEMPERATURE	80°C / 176°F	80°C / 176°F
RECOMMENDED MESH STRAINER SIZE	60 MESH	60 MESH

**Port Size** To order flowmeter you must replace 'X' with the relevant number. This number will determine the following specifications:

**Port Size:**

- 3 = 2" ANSI 150lb Flange
- 4 = 2" ANSI 150lb Flange
- 5 = 50mm DIN 16 Flange

**Calibrated and Display In:**

- Litres
- US Gallons
- Litres

PPS = Polyphenylene Sulfide Resins



# M50 - 2" PULSE METERS WITH STANDARD LC DISPLAY

# TYPE M50 - 2" PULSE METERS

## Weights

MODEL	M5OARG-3	M5OARG-4	M5OARG-5	M5OSRG-3	M5OSRG-4	M5OSRG-5
WEIGHT	10kg / 22lbs	10kg / 22lbs	10kg / 22lbs	23kg / 50.60lbs	23kg / 50.60lbs	23kg / 50.60lbs

## Options & Accessories

M50 - 2" METER STD LC DISPLAY	VITON O-RING	TEFLON O-RING	EPDM O-RING	HIGH TEMP ROTORS	HIGH VISCOSITY ROTORS	HALL EFFECT SENSOR	REED SWITCH	SOLVENT KIT	HASTALLOY C SHAFTS	PROTECTIVE BOOT	EXTENDED LIFE BATTERY	REMOTE MOUNTED LC DISPLAY	HEATING JACKET	4-20mA MODULE
M5OARG-X	O	O	O	O	O	O	S	X	X	X	X	O	A	A
M5OSRG-X	O	O	O	O	O	O	S	X	X	X	X	O	A	A

S = Standard

O = Optional

X = Not Available

A = Accessory

## Dimensions

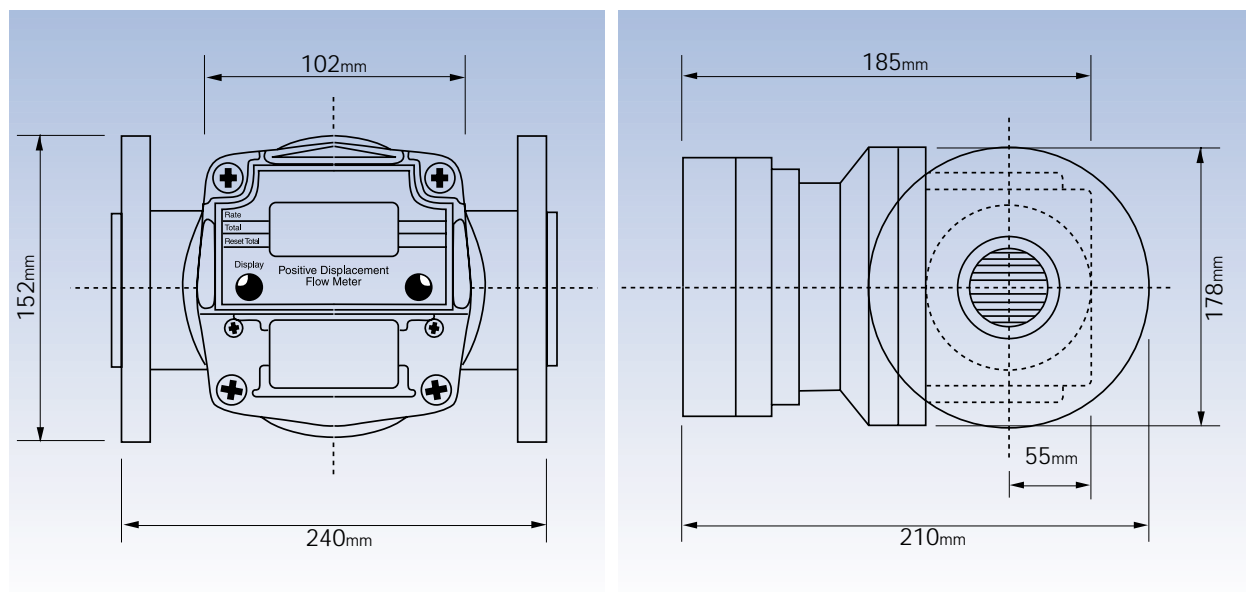

# M50 - 2" PULSE METERS WITH DELUXE LC DISPLAY

The M50 is the largest capacity meter in the M Series range. It has the ability to handle a wide range of fluid viscosities with exceptional levels of repeatability and durability.



**M50ARE-3**

## Product Benefits

- Compact size.
- Flexibility of installation options (e.g. can be mounted horizontally or vertically; no flow conditioning required).
- Low pressure drop allows for economical pump selection or gravity flow applications.
- Has IP54/NEMA13 protection.
- Meter construction enables fast and easy on-site servicing without removal from application.
- Meter accuracy is verified by a factory calibration check after which an individual metrology report is issued.
- Built in auxiliary pulse output available.
- Meter design minimises the number of wearable and replaceable parts and extends product life.
- Intrinsically safe LC Display. Certificate of conformity number PTB Nr. Ex-93.C.4033x.
- LC Display meets European CE directive.
- Will handle particle sizes to 0.46mm/0.018".

MODEL	M50ARE-X	M50SRE-X
METER TYPE	PULSE WITH DELUXE LC DISPLAY	PULSE WITH DELUXE LC DISPLAY
METER BODY MATERIAL	AA601 ALUMINIUM	316 STAINLESS STEEL
WETTED COMPONENTS: ROTOR MATERIAL SHAFTS O-RING	PPS 316 STAINLESS STEEL NBR (NITRILE)	PPS 316 STAINLESS STEEL NBR (NITRILE)
FLOW RATE RANGES (litres per minute/US gallons per minute) ABOVE 5 CPS BELOW 5 CPS	15 to 350 / 3.96 to 92.46 30 to 300 / 7.93 to 79.25	15 to 350 / 3.96 to 92.46 30 to 300 / 7.93 to 79.25
ACCURACY- WITHIN (OF READING)	+/- 0.5%	+/- 0.5%
REPEATABILITY	0.03%	0.03%
MAXIMUM VISCOSITY (OF STANDARD MODEL)	1000 Centipoise	1000 Centipoise
MAXIMUM OPERATING PRESSURE	AS PER FLANGE RULE	AS PER FLANGE RULE
PULSER TYPE	REED SWITCH OR COMBINATION HE / RS	REED SWITCH OR COMBINATION HE / RS
PULSES PER LITRE/US GALLONS	6.68 / 25.29	6.68 / 25.29
MAX. OPERATING TEMPERATURE	80°C / 176°F	80°C / 176°F
RECOMMENDED MESH STRAINER SIZE	60 MESH	60 MESH

**Port Size** To order flowmeter you must replace 'X' with the relevant number. This number will determine the following specifications:

**Port Size:**

- 3 = 2" ANSI 150lb Flange
- 4 = 2" ANSI 150lb Flange
- 5 = 50mm DIN 16 Flange

**Calibrated and Display In:**

- Litres
- US Gallons
- Litres

PPS = Polyphenylene Sulfide Resins



# M50 - 2" PULSE METERS WITH DELUXE LC DISPLAY

# TYPE M50 - 2" PULSE METERS

## Weights

MODEL	M50ARE-3	M50ARE-4	M50ARE-5	M50SRE-3	M50SRE-4	M50SRE-5
WEIGHT	10kg / 22lbs	10kg / 22lbs	10kg / 22lbs	23kg / 50.60lbs	23kg / 50.60lbs	23kg / 50.60lbs

## Options & Accessories

M50 - 2" METER DLX LC DISPLAY	VITON O-RING	TEFLON O-RING	EPDM O-RING	HIGH TEMP ROTORS	HIGH VISCOSITY ROTORS	HALL EFFECT SENSOR	REED SWITCH	SOLVENT KIT	HASTALLOY C SHAFTS	PROTECTIVE BOOT	EXTENDED LIFE BATTERY	REMOTE MOUNTED LC DISPLAY	HEATING JACKET	4-20mA MODULE
M50ARE-X	O	O	O	O	O	O	S	X	X	A	A	A	A	A
M50SRE-X	O	O	O	O	O	O	S	X	X	A	A	A	A	A

S = Standard

O = Optional

X = Not Available

A = Accessory

## Dimensions

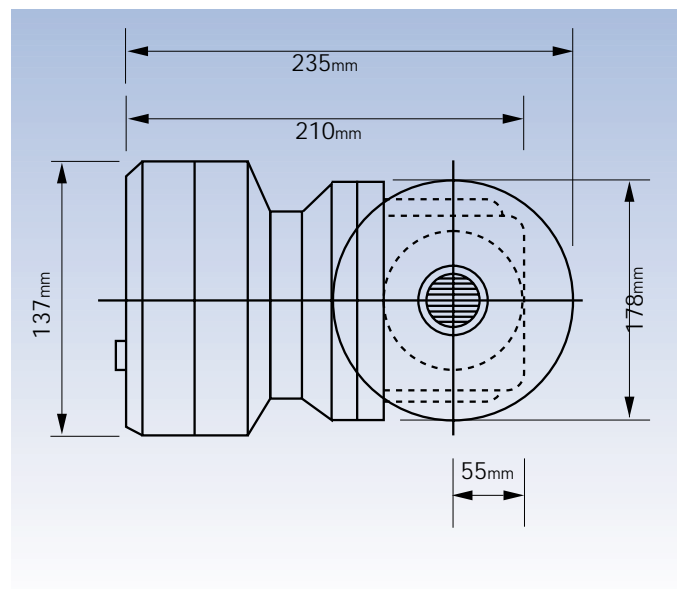
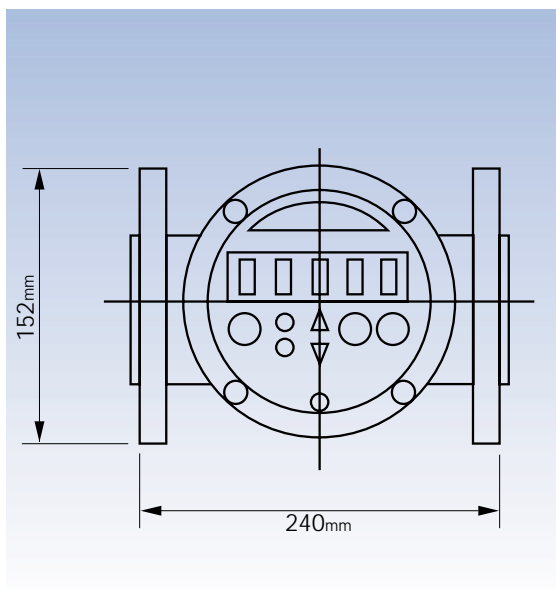

# M50 - 2" METERS WITH MECHANICAL DISPLAY

The M50 is the medium to large capacity meter in the M Series range. It has the ability to handle a wide range of fluid viscosities with exceptional levels of repeatability and durability.



**M50ARM-3**

## Product Benefits

- Compact size.
- Easy to read and operate mechanical display.
- Flexibility of installation options (e.g. can be mounted horizontally or vertically; no flow conditioning required).
- Low pressure drop allows for economical pump selection or gravity flow applications.
- Meter construction enables fast and easy on-site servicing without removal from application.
- Meter accuracy is verified by a factory calibration check after which an individual metrology report is issued.
- Meter design minimises the number of wearable and replaceable parts and extends product life.
- Will handle particle sizes to 0.38mm/0.015".

MODEL	M50ARM-X	M50SRM-X
METER TYPE	METER WITH MECHANICAL DISPLAY	METER WITH MECHANICAL DISPLAY
METER BODY MATERIAL	AA601 ALUMINIUM	316 STAINLESS STEEL
WETTED COMPONENTS: ROTOR MATERIAL SHAFTS O-RING	PPS 316 STAINLESS STEEL NBR (NITRILE)	PPS 316 STAINLESS STEEL NBR (NITRILE)
FLOW RATE RANGES (litres per minute/US gallons per minute) ABOVE 5 CPS BELOW 5 CPS	15 to 350 / 3.96 to 92.46 30 to 300 / 7.93 to 79.25	15 to 350 / 3.96 to 92.46 30 to 300 / 7.93 to 79.25
ACCURACY- WITHIN (OF READING)	+/- 1%	+/- 1%
REPEATABILITY	0.03%	0.03%
MAXIMUM VISCOSITY (OF STANDARD MODEL)	1000 Centipoise	1000 Centipoise
MAXIMUM OPERATING PRESSURE	AS PER FLANGE RULE	AS PER FLANGE RULE
MAX. OPERATING TEMPERATURE	80°C / 176°F	80°C / 176°F
RECOMMENDED MESH STRAINER SIZE	60 MESH	60 MESH

**Port Size** To order flowmeter you must replace 'X' with the relevant number. This number will determine the following specifications:

**Port Size:**

- 3 = 2" ANSI 150lb Flange
- 4 = 2" ANSI 150lb Flange
- 5 = 50mm DIN 16 Flange

**Calibrated and Display In:**

- Litres
- US Gallons
- Litres

PPS = Polyphenylene Sulfide Resins



# M50 - 2" METERS WITH MECHANICAL DISPLAY

TYPE M50 - 2" METERS

## Weights

MODEL	M50ARM-3	M50ARM-4	M50ARM-5	M50SRM-3	M50SRM-4	M50SRM-5
WEIGHT	7.28kg / 16lbs	7.28kg / 16lbs	7.28kg / 16lbs	18.38kg / 41.50lbs	18.38kg / 41.50lbs	18.38kg / 41.50lbs

## Options & Accessories

M50 - 2" MECHANICAL DISPLAY	VITON O-RING	TEFLON O-RING	EPDM O-RING	HIGH TEMP ROTORS	HIGH VISCOSITY ROTORS	HALL EFFECT SENSOR	REED SWITCH	SOLVENT KIT	HASTALLOY C SHAFTS	PROTECTIVE BOOT	EXTENDED LIFE BATTERY	REMOTE MOUNTED LC DISPLAY	HEATING JACKET	4-20mA MODULE
M50ARM-X	O	O	O	O	O	X	X	O	X	X	X	X	A	X
M50SRM-X	O	O	O	O	O	X	X	S	X	X	X	X	A	X

S = Standard

O = Optional

X = Not Available

A = Accessory

## Dimensions

