

General Specifications

General Purpose Model
IR800G, IR810G
Infrared Gas Analyzer

GS 11G06A01-01EN

■ GENERAL

The IR800G, IR810G Infrared Gas Analyzer uses non-dispersive infrared method (NDIR) to measure the concentration of NO, SO₂, CO, CO₂, and CH₄ components in the sample gas, and it measures O₂ using the paramagnetic or zirconia method.

Up to five components, including O₂ (up to four components excluding O₂), can be measured simultaneously.

Using a single beam system for measurement ensures low maintenance requirements to maintain the zero point and excellent stability over a long period of time.

The color touch panel interface allows for intuitive operation and high visibility.

Ideal for measuring gas concentrations in combustible gases emitted from incinerators, boilers, and various industrial furnaces.



IR800G



IR810G

■ FEATURES

- **Up to 5 gas components measurement**
Simultaneous measurement of gas concentrations of up to five components: four of NO, SO₂, CO₂, CO, CH₄, and O₂.
- **Excellent long-term stability**
A unique optics system minimizes drift particularly due to contamination of measurement cell, ensuring excellent long-term stability.
- **Easy operation**
Intuitive operation by the color touch panel display. Error display for easy visibility. Error details can be checked on the display.
- **Connectable to ZR802G, etc. as oxygen analyzer**
Supports 4-20 mA analog input for oxygen concentration measurement, allowing connection to Yokogawa Electric's ZR802G zirconia oxygen analyzer, etc.
- **Output signal: 4-20mA**
- **Supports digital communication**
Modbus RTU
- **Automatic validation function**
Automatically distributes the gas used for calibration and records the values at the time of the gas distribution. Examines the condition of the detector and the appropriate maintenance cycle.

The company and product names mentioned in this document are trademarks or registered trademarks of their respective companies.

■ Example of sampling configuration including analyzer

When the reference gas is instrument air, N₂

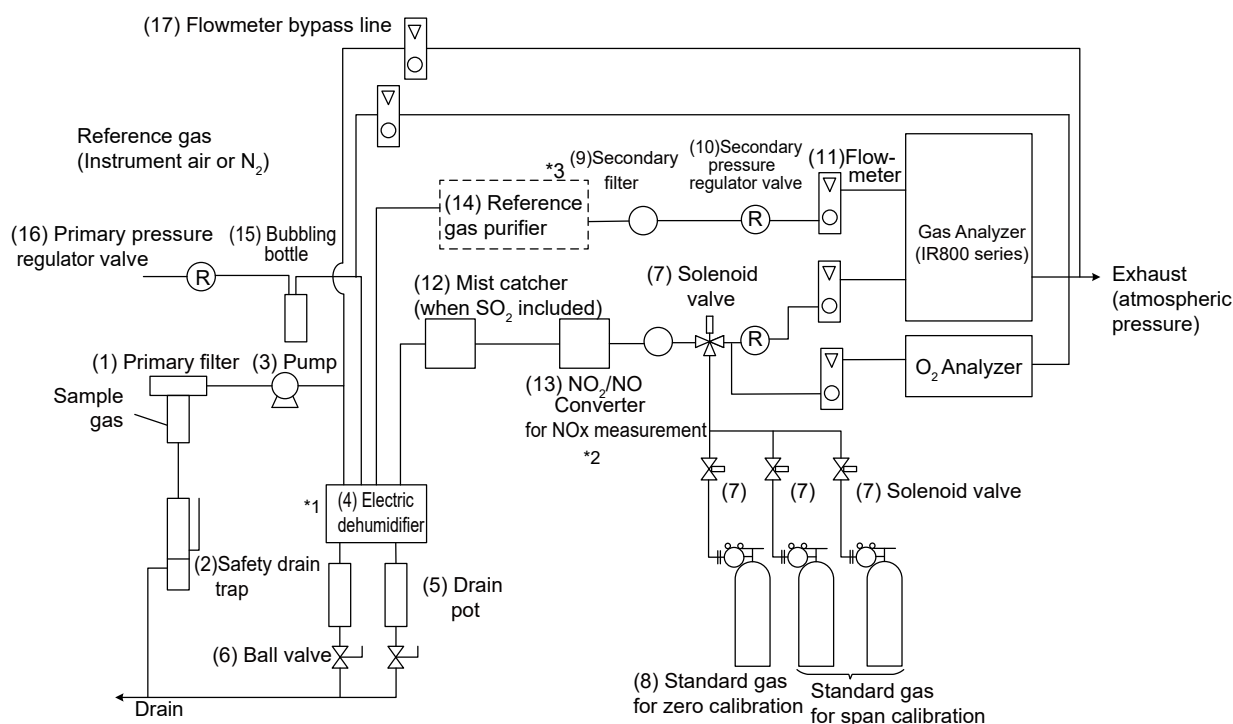

*1: In electric dehumidifiers, dehumidify to 5°C or less so that the moisture concentration on the sampling and reference sides is the same.

*2: NO₂/NO converter is used for NO_x measurement.
Provide K9350LE or a compliant product; K9350LF is not available as a CE compliant product.

*3: Whether or not a reference gas purifier is required is determined by the concentration of the measured component in the reference gas.
If the concentration of the measured gas in the reference gas is less than 0.1% F.S. of the range, a reference gas purifier is not required.

If the atmosphere is used as the reference gas and the range is less than or equal to the ranges below, the use of a reference gas purifier is recommended.

NO: 0-100 ppm or less, SO₂: 0-50 ppm or less, CO: 0-1000 ppm or less

Contact us for a reference gas purifier for each component.

When CO₂ (Low range) level is 0-0.1 vol% to 0-5 vol%, N₂ should be used as reference gas. (Both atmosphere and instrument air are unacceptable.)

Item	Function	Item	Function
(1) Primary filter	Removes dust and mist from sample gas	(10) Pressure regulator valve	Adjusts pressure to 5-10 kPa. Variation to the set pressure is $\pm 2\%$.
(2) Safety drain trap	Separates and discharges the drainage in sample gas	(11) Flowmeter	Monitors the flow rate of gas entering the gas analyzer.
(3) Pump	For sample gas intake	(12) Mist catcher	Collects sulfuric acid mist in the sample gas.
(4) Electric dehumidifier	Dehumidifies moisture in sample gas	(13) NO ₂ /NO converter	Convert NO ₂ to NO.
(5) Drain pot	Traps dehumidified water from the electronic dehumidifier.	(14) Reference gas purifier	Removes interference components in the comparison gas.
(6) Ball valve	For draining	(15) Bubbling bottle	Humidifies reference gases
(7) Solenoid valve	Switches the calibration gas and sample gas flow channel.	(16) Primary pressure regulator valve	Adjusts the pressure to correspond to the inlet pressure of (10).
(8) Standard gas for calibration	Reference gas to calibrate zero and span Used according to measurement component Adjusts the pressure to correspond to the inlet pressure of (10).	(17) Flowmeter bypass line	Monitors and controls the flow rate of bypass lines.
(9) Secondary filter	Removes particulates from reference gas purifiers and NO ₂ /NO converters.		

■ Standard Specifications

Measurement principle:

NO, SO₂, CO₂, CO, CH₄:
Non-dispersive infrared method
Single light source-single beam

O₂: Paramagnetic type (built-in), or analog input (external)

Measurable gas components and measurement range:

Table 1 Measurement range

	General Range	Optional range*
NO	0-200 to 0-5000 ppm	0-50 to 0-199 ppm
SO ₂	0-200 to 0-5000 ppm	0-50 to 0-199 ppm
	0-2 to 0-10 vol%	—
CO	0-200 to 0-5000 ppm	0-50 to 0-199 ppm
	0-2 to 0-50 vol%	0-51 to 0-100 vol%
CO ₂	0-0.5 to 0-5 vol%	0-1000 to 0-4999 ppm
	0-5 to 0-25 vol%	0-26 to 0-100 vol%
CH ₄	0-2 to 0-50 vol%	0-51 to 0-100 vol%

* Measurement accuracy varies in optional ranges.
See "Performance" page 5

Table 2 O₂ analyzer

	Min.range	Max.range
O ₂ Built-in paramagnetic type	0-5 vol%	0-100 vol%
O ₂ Built-in paramagnetic type for hydrogen background	0-25 vol%	0-100 vol%
O ₂ External analyzer	0-5 vol%	0-100 vol%

Display: QVGA LCD color touch panel
(Note) Due to the characteristics of the panel, chips, afterimages, and uneven brightness may appear on the display screen, but these are not defects.

- 4-digit display
- Instantaneous value display for each component
- Instantaneous value after O₂ correction (only in CO, SO₂, NO meters with O₂ measurement)
- Average value after O₂ correction (only in CO, SO₂, NO meters with O₂ measurement)

Analog output:

Isolated output: 4-20 mA DC
Maximum load capacity: 550 Ω
Number of outputs: 4
Output Item: NAMUR NE43 burnout
Hold function: available

Analog input (when O₂ analyzer: -1 or -2 is selected)

Number of input points;
1 point (for connection to external O₂ analyzer)

Input signal: 4-20 mA DC (Max 40 mA)
Functions: Oxygen concentration display, oxygen concentration conversion

Contact output:

Contact type; 1a relay contact, 1c relay contact
Output points;
1a; 11 points
1c; 6 points
Contact capacity;
250 V AC, 2A (resistance load)
24 V DC, 1A (resistance load)
AC/DC power sources cannot be mixed.

Insulation;

Internal circuit: Reinforced insulation
Between contacts: Basic insulation

Function; Instrument error, Calibration error, Automatic calibration in progress, Solenoid valve drive CH1 to CH5 for automatic calibration, Range identification CH1 to CH5, Blowback, alarms 1 to 6, Peak alarm output, Maintenance in progress, Power status

Contact input:

Contact type; no-voltage or voltage contact input
Input points; 8 points
On/Off;
No-voltage contact input
Resistance value below 200 Ω; closed
Resistance value of 100 kΩ or more; open
Voltage contact input
Voltage -1 to +1 V DC; closed
Voltage value +4.5 to +25 V DC; open
Contact capacity: Leakage current 3 mA or less when OFF

Insulation;

Contacts mutual; non-insulating
Internal circuit; transformer isolation
Function; Remote hold, average value reset, automatic calibration start, auto zero calibration start, automatic validation start, remote range changeover, blowback contact for ZR802G, calibration error for ZR802G

Digital Communications:

RS-485 (Modbus RTU); 115200/38400/9600 bps
Cable length; Up to 600 m (115200 bps)
Up to 1200 m (38400/9600 bps)

Shield ground

Operating conditions:

Ambient temperature; 0 to 40°C (IR800G)
0 to 45°C (IR810G)
Ambient humidity; 10 to 90%RH
(at 40°C, no condensation)
Storage temperature -10 to +50°C
Storage humidity; 35 to 85%R.H. (no condensation)

Power Supply voltage:

Voltage rating; 100 to 240 V AC
Allowable range; 85 to 264 V AC

Power Supply Frequency;

Rated frequency; 50/60 Hz
Allowable range; 47 to 63 Hz

Power Consumption

IR800G; Max. 110 VA
IR810G; Max. 110 VA

Dimensions (W x D x H):

IR800G; 483 x 492 x 177 mm
IR810G; 412 x 240 x 615 mm

Weight:

IR800G; approx. 16 kg
IR810G; approx. 17 kg

Finish color:

silver gray

Enclosure:

steel casing, for indoor use

Material of gas-contacting parts:

Gas inlet/outlet; 316SS (stainless steel)
Internal tubing; 304SS, 316SS, Fluoropolymer (PTFE, PFA), PP, PPS, fluoroelastomer, calcium fluoride (CaF₂), PEEK (only for O₂ Analyzer "-3" or "-4")

Gas inlet/outlet:

Rc1/4 or 1/4 NPT internal thread

Purge gas flow rate:

approx. 1 L/min (when necessary)

Safety, EMC and RoHS conformity standards

Safety conformity standards:

CE, UKCA	EN 61010-1, EN IEC 61010-2-030
UL	UL 61010-1, UL 61010-2-030
CSA	CAN/CSA-C22.2 No.61010-1, 61010-2-030
GB	GB30439

Installation altitude: 2000 m or less

Installation category; (IEC 61010)II (Note 1)

Pollution degree; (IEC 61010); 2 (Note 2)

Note1: Installation category, so called overvoltage category, specifies impulse withstanding voltage. Category II overvoltage applies to equipment intended to be powered from the building wiring.

Note2: Pollution degree indicates the degree of existence of solid, liquid, gas or other inclusions which may reduce dielectric strength. Degree 2 indicates the normal indoor environment.

EMC:

CE, UKCA EN61326-1 Class A, Table 2 (For use in industrial locations)

EN61326-2-3, EN61000-3-2, EN IEC 61000-3-2, EN61000-3-3

RCM EN61326-1 CLASS A, Table2

KC Korea Electromagnetic Conformity Standard Class A

한국 전자과적합성 기준

Note: · This instrument is a Class A product, and it is designed for use in the industrial environment. Please use this instrument in the industrial environment only.

· Influence of immunity environment (Criteria A): Output shift is specified within $\pm 15\%$ of F.S.

Environmental regulation:

RoHS; EN IEC 63000

Information of the WEEE Directive;

This product is purposely designed to be used in a large scale fixed installations only and, therefore, is out of scope of the WEEE Directive. The WEEE Directive does not apply. The WEEE Directive is only valid in the EU/UK.

REACH; Regulation EC 1907/2006

Standard Functions

Output signal hold: Measured value output can be held during calibration or operation by automatic or on-screen operation, or by remote execution instructions. The output at hold can be selected from the previous value and the set value.

Range changeover: The output range of measured values can be changed automatically or manually. Range changeover can also be turned off.

Range identification signal: When using the range changeover function, it is possible to output whether the low or high range is being used.

Blowback: Can open/close the contact output for blowback by a scheduled cycle or by an execution command. Blowback can set the blowback time and the gas displacement time after blowback (output hold time).

Auto calibration: Can be calibrated automatically by scheduled cycles or execution commands. If the calibration coefficient is outside the normal range, an alarm is issued. The alarm can be assigned to a contact output.

Auto zero calibration: Separate from the schedule set for Auto calibration, Auto calibration for Zero Point only can be set. If the timing of Auto calibration and the Auto zero calibration are to occur at the same time, the Auto calibration takes precedence.

Auto validation: -V is selected, the automatic validation function is available. The automatic validation function flows the calibration gas through the measurement line and records the measured value according to a scheduled cycle or execution command. If the measured value deviates from the set threshold value, an alarm can be issued and the alarm can be assigned to a contact output. This function allows the user to verify the normality of the instrument.

Contact output during auto-calibration/validation: Displays the status of automatic calibration and validation. Status can be assigned to a contact output.

High/low limit alarm: Upper or lower thresholds can be set and alarmed if exceeded. Alarms can be assigned to contact outputs.

Instrument error contact output: If an instrument error occurs, an alarm is issued. The alarm is assigned to a contact output.

Calibration error contact output: If calibration is not performed properly, an alarm is issued. The alarm is assigned to a contact output

Optional Functions

IR800G, IR810G common

/U: unit conversion (mg/m^3 , g/m^3)

Changes the units for instantaneous values, O_2 conversion, and average values of NO , SO_2 , and CO to mg/m^3 or g/m^3 . If the measurement range is set to vol%, no conversion is made. See Table 3 for the corresponding values.

Table 3 ppm-mg/m³ range

ppm range	Corresponding range in mg/m ³		
	NO	SO ₂	CO
0-50 ppm	0-65.0 mg/m ³	0-140 mg/m ³	0-60.0 mg/m ³
0-100 ppm	0-130 mg/m ³	0-280 mg/m ³	0-125 mg/m ³
0-200 ppm	0-260 mg/m ³	0-570 mg/m ³	0-250 mg/m ³
0-250 ppm	0-325 mg/m ³	0-700 mg/m ³	0-300 mg/m ³
0-300 ppm	0-400 mg/m ³	0-850 mg/m ³	0-375 mg/m ³
0-500 ppm	0-650 mg/m ³	0-1400 mg/m ³	0-600 mg/m ³
0-1000 ppm	0-1300 mg/m ³	0-2800 mg/m ³	0-1250 mg/m ³
0-2000 ppm	0-2600 mg/m ³	0-5600 mg/m ³	0-2500 mg/m ³
0-2500 ppm	0-3300 mg/m ³	0-7100 mg/m ³	0-3000 mg/m ³
0-3000 ppm	0-4000 mg/m ³	0-8500 mg/m ³	0-3750 mg/m ³
0-5000 ppm	0-6600 mg/m ³	0-14.00 g/m ³	0-6250 mg/m ³

/P: Analyzer internal purge port:

For the following cases, /P should be selected.

- When the sample gas contains combustible gas
- When corrosive gases are present in the atmosphere at the installation site.
- When the atmosphere at the installation site contains the same gases as the measured component.

Use dry N_2 or instrument air free of dust or mist as the purge gas. The required flow rate is approximately 1 L/min.

/A: CO Peak Alarm:

An alarm is issued when the number of times the measured concentration of CO peaks above the upper limit exceeds the set value. The alarm is assigned to a contact output.

/K: O₂ correction; Instantaneous O₂ correction values and O₂ correction average values of NO, SO₂, and CO can be calculated and output.

/NX: NO on the measurement screen is displayed as NOx: NO is displayed as NOx. /U. When used in conjunction with /U, the units are converted as NO

/PR: Pressure regulator valve
(Set for sample gas/ reference gas):
Includes one pressure regulator valve for reference gas and one for sample gas.

Pressure regulator valve for sample gas

Part Number: K8019GA
Inlet pressure: 7 to 18 kPa
Outlet pressure: 5±0.05 kPa

Gas contact material: Stainless steel
Pipe connection: Ø6 mm/Ø4 mm PTFE tube

Pressure regulator valve specifications for reference gas

Part Number: K8019GB
Inlet pressure: 7 to 18 kPa
Outlet pressure: 5±0.05 kPa

Gas contact material: aluminum
Pipe connection: ø6 mm/ø4 mm PTFE tube

IR810G only

/CG1~/CG4:

Cable gland for wiring;
Cable gland for wiring is included. If you do not provide your own, please select the required number of cable glands.

/RP IR202-B:

Sheet metal for wall-mounted replacement;
Select this option when installing the same dimensions as IR202-B.

Performance

NO/SO₂/CO/CO₂/CH₄

Repeatability: ±0.5% F.S.
(±1% F.S. when the optional range is included)

Linearity: ±1% F.S.

Zero drift: ±1.0% F.S./week
(±2% F.S./week when the optional range is included)

Span drift: ±2.0% F.S./week

Response time (90% F.S. response): 30 sec. or less

Interference: ±2.0% F.S. (for sample gas condition in Table 4)

Table 4 Sample gas conditions

Ambient temperature	10 to 50°C	
Ambient humidity	90%RH or lower	
Sample gas conditions	Dust	2 µm or lower
	NO	1000 ppm or less
	SO ₂	1000 ppm or less
	SO ₃	Unallowable
	CO	500 ppm or less
	CH ₄	500 ppm or less
	CO ₂	15 vol% or lower
	O ₂	25 vol% or lower
No other corrosive gas		

Built-in paramagnetic oxygen analyzer

Repeatability: ±0.5% F.S.

Linearity: ±1% F.S.

Zero drift: ±2% F.S./week

Span drift: ±2% F.S./week

Response time (90% F.S. response): 30 sec. or less

Sample gas conditions

Flow rate: 0.5 to 1.0 L/min

Temperature: 0 to 50°C

Pressure: 4.9 to 9.8 kPa (Gas outlet side should be open to the atmospheric air. The pressure fluctuation relative to the set pressure shall be within ±2%.)

Dust: 2 µm or less in particle size

Mist: Unallowable

Moisture: Below a level where saturation occurs at 5°C (No condensation)

No other corrosive gas

Reference gas conditions

Gas: Atmosphere, instrument air or N₂

Flow rate: 0.5 to 1.0 L/min

Temperature: 0 to 50°C

Pressure: 4.9 to 9.8 kPa (Gas outlet side should be open to the atmospheric air. The pressure fluctuation relative to the set pressure shall be within ±2%.)

Dust: 2 µm or less in particle size

Mist: Unallowable

Moisture: Below a level where saturation occurs at 5°C (No condensation)

Impurities other than CO₂:
0.1% F.S. or less of minimum measurement range.

When the measurement range of the CO₂ meter is C1, C2, C3, or C4, be sure to use N₂ as the reference gas.

Standard gas for calibration

Zero gas: Dry N₂

Span gas: 80 - 90% concentration of the range of each component to be measured (recommended)
Concentrations above 105% F.S. are not allowed.

Dry Air or Atmosphere can be used as the span gas for the O₂ analyzer.

However, if a zirconia type O₂ analyzer manufactured by YOKOGAWA is installed externally and calibrated with the same calibration gas line, use 1 to 2 vol% O₂ as Zero gas.

Installation Requirements

- Indoor use: Avoid exposure to direct sunlight, weather, and radiant heat from hot substances. Where exposure to such conditions is unavoidable, a protective hood or cover should be prepared.
- Vibration-free environment
- A clean atmosphere

■ Model and Suffix Code

IR800G

Model	Suffix code	Option code	Specification
IR800G			Rack Type Infrared Gas Analyzer
Type	-AJ -AB -AD -AG	-----	General (Japan) General (CE, UKCA, RCM, GB) General (CSA) General (KC)
Measuring Components	-A1 -A2 -A3 -A4 -A5 -B1 -B2 -B4 -B5 -B6 -C1 -C4 -D1	-----	NO SO ₂ CO CO ₂ CH ₄ NO+SO ₂ NO+CO CO+CO ₂ CO+CH ₄ CO ₂ +CH ₄ NO+SO ₂ +CO CO+CO ₂ +CH ₄ NO+SO ₂ +CO+CO ₂
O ₂ Analyzer	-N -1 -2 -3 -4	-----	None ZR802G+ZR22G (*1) External O ₂ analyzer (*1) Built-in paramagnetic O ₂ Built-in paramagnetic O ₂ (H ₂ background) (*2)
NO Measuring Range	- □□	-----	See "■ Measuring gas range"
SO ₂ Measuring Range	- □□	-----	See "■ Measuring gas range"
CO Measuring Range	- □□	-----	See "■ Measuring gas range"
CO ₂ Measuring Range	- □□	-----	See "■ Measuring gas range"
CH ₄ Measuring Range	- □□	-----	See "■ Measuring gas range"
O ₂ Measuring Range	- □□	-----	See "■ Measuring gas range"
Digital Communication	-N -R	-----	None RS-485
Automatic Validation	-N -V	-----	None Automatic Validation
Gas connection	-R -T	-----	Rc1/4 1/4NPT
Display Language	-E -C -J	-----	English Chinese Japanese
Mount Type	-S -R	-----	Rack with slide rail Rack without slide rail
—	-NN	-----	Always "-NN"
—	-NN	-----	Always "-NN"
Option		/U /P /A /K /NX /PR	Unit change (mg/m ³ , g/m ³) (*3) Air purging inlet Peak alarm (*4) O ₂ compensation (*5) Display NO _x instead of NO (*6) Pressure Regulator (For sample/reference gas line, Pair) (*7)

(*1) Oxygen analyzer is not included. Please arrange it separately.

(*2) If the sample gas contains more than 100 ppm hydrogen, select the "-4" specification for H₂ background.

(*3) Select this option when one or more of NO, SO₂, or CO is included in the measuring component.

(*4) Available when CO is included in the measuring component.

(*5) Available when the O₂ analyzer specification is other than "-N" and one or more of NO, SO₂, or CO is included in the measuring component.

(*6) NO_x converter is not included. Provide K9350LE or a compliant product. K9350LF is not available as a CE compliant product.

(*7) One pressure regulator valve for the sample gas and one for the reference gas are included. Select this option if input pressure is not stable.

See "<Items specified at order IR800G, IR810G>" page 9.

Accessories

Name	Qty	Code Specification	Description
Fuse	2	Pre-installed in equipment	250 V/5 A delay type 5×20 mm IEC 60127-2 sheet 3
Slide rail	2	Mount type "-S"	For 19-inch rack mounting
Thread conversion connector	4	Gas connection "-T"	Rc 1/4 male to 1/4 NPT female
Thread conversion connector	5	Gas connection "-T" and "/P" (Air purging inlet)	Rc 1/4 male to 1/4 NPT female
Pressure Regulator	1	"/PR" For Sample/Reference gas line, Pair	Pressure Regulator (Stainless)
	1		Pressure Regulator (Aluminium)

Spare Parts

Name	Part No.	Qty	Name	Part No.	Qty
C-type snap ring	Y9011EV	1 (*1)	Filter	K8020PW	1
Plate	K9213FB	1	Snap ring plier	K9643ZE	1

*1: The minimum purchase quantity is 10 per order.

IR810G

Model	Suffix code	Option code	Specification
IR810G			Wall and Panel Mount Type Infrared Gas Analyzer
Type	-AJ -AB -AD -AG	----- ----- ----- -----	General (Japan) General (CE, UKCA, RCM, GB) General (CSA) General (KC)
Measuring Components	-A1 -A2 -A3 -A4 -A5 -B1 -B2 -B4 -B5 -B6 -C1 -C4 -D1	----- ----- ----- ----- ----- ----- ----- ----- ----- ----- ----- ----- -----	NO SO ₂ CO CO ₂ CH ₄ NO+SO ₂ NO+CO CO+CO ₂ CO+CH ₄ CO ₂ +CH ₄ NO+SO ₂ +CO CO+CO ₂ +CH ₄ NO+SO ₂ +CO+CO ₂
O ₂ Analyzer	-N -1 -2 -3 -4	----- ----- ----- ----- -----	None ZR802G+ZR22G (*1) External O ₂ analyzer (*1) Built-in paramagnetic O ₂ Built-in paramagnetic O ₂ (H ₂ background) (*2)
NO Measuring Range	- □□	-----	See "■Measuring gas range"
SO ₂ Measuring Range	- □□	-----	See "■Measuring gas range"
CO Measuring Range	- □□	-----	See "■Measuring gas range"
CO ₂ Measuring Range	- □□	-----	See "■Measuring gas range"
CH ₄ Measuring Range	- □□	-----	See "■Measuring gas range"
O ₂ Measuring Range	- □□	-----	See "■Measuring gas range"
Digital Communication	-N -R	----- -----	None RS-485
Automatic Validation	-N -V	----- -----	None Automatic Validation
Gas connection	-R -T	----- -----	Rc1/4 1/4NPT
Display Language	-E -C -J	----- ----- -----	English Chinese Japanese
Mount Type	-P -W	----- -----	Panel mount Wall mount
—	-NN	-----	Always "-NN"
—	-NN	-----	Always "-NN"
Option		/U /P /CG1 /CG2 /CG3 /CG4 /A /K /NX /RP /PR	Unit change (mg/m ³ , g/m ³) (*3) Air purging inlet Cable glands for wiring x 6 (*4) Cable glands for wiring x 10 (*4) Cable glands for wiring x 12 (*4) Cable glands for wiring x 16 (*4) Peak alarm (*5) O ₂ compensation (*6) Display NOx instead of NO (*7) IR202-B compatible wall mount conversion plate (*8) Pressure Regulator (For sample/reference gas line, Pair) (*9)

(*1) Oxygen analyzer is not included. Please arrange it separately.

(*2) If the sample gas contains more than 100 ppm hydrogen, select the "-4" specification for H₂ background.

(*3) Select this option when one or more of NO, SO₂, or CO is included in the measuring component.

(*4) Select the amount you need. The following is for reference only.

/CG1: Wiring only RS-485 and power supply

/CG2: 1-2 Component measurement

/CG3: Three or more component measurements without RS-485 or without external zirconia (ZR802G+ZR22G)/external oxygen analyzer

/CG4: Other than the above

When using cable glands other than /CG1 to /CG4, prepare ones with high flame retardant of UL94 V-2 or higher, heat resistance temperature of 85°C or higher, and thread size of M20 x 1.5.

(*5) Available only when CO is included in the measuring component.

(*6) Available when the O₂ analyzer specification is other than "-N" and one or more of NO, SO₂, or CO is included in the measuring component.

(*7) NOx converter is not included; provide K9350LE or a compliant product. K9350LF is not available as a CE compliant product.

(*8) Available when the mount type is "-W" wall mount.

(*9) One pressure regulator valve for the sample gas and one for the reference gas are included. Select this option if input pressure is not stable.

See "<Items specified at order IR800G, IR810G>" page 9 .

Accessories

Name	Qty	Code Specification	Description
Fuse	2	Pre-installed in equipment	250 V/5 A delay type 5×20 mm IEC 60127-2 sheet3
Ferrite Cores for Power Cable	1	—	—
Panel mounting bracket	4	Mount type "-P"	—
Cable clip	2	none	—
Screw for fixing cable clip	2	none	M5, 8 mm length
Bolt	4	"-W"	M8, 35 mm length
Washer	8	"-W"	M8
Nut	4	"-W"	M8
Thread conversion connector	4	Gas connection "-T"	Rc 1/4 male to 1/4 NPT female
Thread conversion connector	5	Gas connection "-T" and "/P" (Air purging inlet)	Rc 1/4 male to 1/4 NPT female
Cable glands	6	"/CG1" Cable glands for wiring x6	Applicable cable diameter: Ø6.5 to Ø12mm Connecting thread : M20×1.5
Cable glands	10	"/CG2" Cable glands for wiring x10	
Cable glands	12	"/CG3" Cable glands for wiring x12	
Cable glands	16	"/CG4" Cable glands for wiring x16	
Bracket	1	"/RP" IR202-B compatible wall mount conversion plate	IR202-B compatible wall mount conversion plate
Screw	4		M6, 10mm length
Pressure Regulator	1	"/PR" For Sample/Reference gas line, Pair	Pressure Regulator (Stainless)
Pressure Regulator	1		Pressure Regulator (Aluminium)

Spare Parts

Name	Part No.	Qty	Name	Part No.	Qty
C-type snap ring	Y9011EV	1 (*1)	Filter	K8020PW	1
Plate	K9213FB	1	Snap ring plier	K9643ZE	1

*1: The minimum purchase quantity is 10 per order.

Optical Unit Parts

Maintenance and replacement of the optical unit are performed by trained service engineers.

Name	Part No.	Qty for 1 unit	Description	Recommended replacement interval (Year)	Applicable model
Packing	K8020QJ	2 (*1)	Packing for Lamp unit	1	All model
Base block	K8020QK	1	Solenoid valve and Capillary mount base	1	All model
Solenoid Valve	A1050MS	2 (*1)	Solenoid Valve for switching sample gas and reference gas	1	All model
Packing	K8020QM	2 (*1)	Packing for Capillary	1	All model
Elbow connector	K8020QB	4 (*1)	Connector for low range Cell	1	Measuring range "-E□"
O-ring	K8020QD	3 (*2)	O-ring for low range cell	1	Measuring range "-E□"
O-ring	K8020QE	2 (*1)	O-ring for low range cell	1	Measuring range "-E□"
O-ring	K8020QF	2 (*1)	O-ring for high range cell	1	Measuring range "-P□"
Elbow connector	K8020QB	2	Connector for high range Cell	1	Measuring range "-P□"
Elbow connector	K8020QH	2 (*1)	Connector for high range Cell	1	Measuring range "-P□"
Spacer	K8020QN	1	Spacer for CO ₂ Cell	1	CO ₂ measurement included model
Sheet	K8020QQ	1	Sheet for CO ₂ Cell	1	CO ₂ measurement included model
O-ring	K8020QF	1	O-ring for CO ₂ Cell (Lamp side)	1	CO ₂ measurement included model
O-ring	K8020QR	1	O-ring for CO ₂ Cell (Detector side)	1	CO ₂ measurement included model
Packing	K8020QS	2	Packing for CO ₂ Cell (Lamp side)	1	CO ₂ measurement included model
Packing	K8020QA	1	Packing for CO ₂ Cell (Detector side)	1	CO ₂ measurement included model
Straight connector (3mm-6mm)	K8020PX	4 or 6 (*3)	3mm-6mm Straight connector	1	All model, Build-in O ₂ model requires 2 extra connectors
Metal hose band for 3mm	K8020PY	10 (*4)	Metal Clip for 3mm hose	1	All model
Metal hose band for 6mm	K8020PZ	10 (*4)	Metal Clip for 6mm hose	1	All model
High range Cell	K8020QG	1	Short measuring cell	2	Measuring range "-P□"
Low range Cell	K8020QC	1	Long measuring cell	3	Measuring range "-E□"
CO ₂ Cell	A1262UY	1	CO ₂ cell for low range	3	CO ₂ measuring range "-C1, -C2, -C3, -C4"
CO ₂ Cell	A1260UY	1	CO ₂ cell for middle range	3	CO ₂ measuring range "-C5"
CO ₂ Cell	A1261UY	1	CO ₂ cell for high range	3	CO ₂ measuring range "-C6"

Name	Part No.	Qty for 1 unit	Description	Recommended replacement interval (Year)	Applicable model
Lamp unit	A1121PE	1	Infrared light source	5	All model
Capillary	K8020QL	2	Capillary for flow control	5	All model
Cell Heater	A1259UY	1	Heater to control cell temperature	5	Measuring range "-E□"

*1: The minimum purchase quantity is 2 per order.

*2: The minimum purchase quantity is 3 per order.

*3: The minimum purchase quantity is 6 per order.

*4: The minimum purchase quantity is 10 per order.

<Items specified at order IR800G, IR810G>

TAGNO. (only if necessary)

You can create TAGNO. (tag number) with alphanumeric characters described in the next table. 16 characters at maximum can be used.

If you specify TAGNO., it is printed on the stainless name plate/tag label affixed to the instrument.

Symbol (Note)	-	Hyphen	_	Underscore
	=	Equal	+	Plus
	/	Slash	:	Colon
	(Left parenthesis)	Right parenthesis
	#	Hash	!	Exclamation mark
	.	Period		
Number	0, 1, 2, 3, 4, 5, 6, 7, 8, 9			
Upper case alphabetic	A, B, C, D, E, F, G, H, I, J, K, L, M, N, O, P, Q, R, S, T, U, V, W, X, Y, Z			
lower case alphabetic	a, b, c, d, e, f, g, h, i, j, k, l, m, n, o, p, q, r, s, t, u, v, w, x, y, z			

(Note): The spaces specified for the TAGNO. are removed. The string is left-squeezed.

■ Measuring gas range

Select the range for the sample gas selected under "Measuring Component". Select "None (-NN)" for gases not included in the measurement component. This product is free-range. You can set the range within the selected measurement range. The measurement accuracy varies when the measurement range is set within the optional range. For details, please refer to "Performance" page 5 .

For multi-component meters, the measurement ranges for NO/SO₂/CO/CH₄ measurement cannot be combined with "-E□" and "-P□" together.

(Example) Measuring component code - B1 (NO+SO₂ meter)

NO measurement range: -E3 (0-200/2000 ppm), SO₂ measurement range: -E6 (0-500/5000 ppm)

=> Both are -E ranges, so they can be combined.

NO measurement range: -E3 (0-200/2000 ppm), SO₂ measurement range: -P1 (0-2/10 vol%)

=> Not possible due to a mix of -E and -P ranges

/U: See Table 3 for unit conversion options.

Table 5 NO

Range	Code	Note
None	-NN	—
0-50/500 ppm	-E1	Optional range
0-100/1000 ppm	-E2	Optional range
0-200/2000 ppm	-E3	—
0-250/2500 ppm	-E4	—
0-300/3000 ppm	-E5	—
0-500/5000 ppm	-E6	—

Table 6 SO₂

Range	Code	Note
None	-NN	—
0-50/500 ppm	-E1	Optional range
0-100/1000 ppm	-E2	Optional range
0-200/2000 ppm	-E3	—
0-250/2500 ppm	-E4	—
0-300/3000 ppm	-E5	—
0-500/5000 ppm	-E6	—
0-2/10 vol%	-P1	—

Table 7 CO

Range	Code	Note
None	-NN	—
0-50/500 ppm	-E1	Optional range
0-100/1000 ppm	-E2	Optional range
0-200/2000 ppm	-E3	—
0-250/2500 ppm	-E4	—
0-300/3000 ppm	-E5	—
0-500/5000 ppm	-E6	—
0-2/20 vol%	-P1	—
0-3/30 vol%	-P2	—
0-5/50 vol%	-P3	—
0-10/100 vol%	-P4	Optional range

Table 8 CO₂

Range	Code	Note
None	NN	—
0-1000/5000 ppm (*1)	-C1	Optional range
0-2000/10000 ppm (*1) (*2)	-C2	Optional range
0-0.5/2.5 vol% (*1) (*3)	-C3	—
0-1/5 vol% (*1)	-C4	—
0-5/25 vol%	-C5	—
0-20/100 vol% (*4)	-C6	Optional range

- (*1) For multi-component meters, other components can only be selected from "-E□□". Always use N₂ for reference gas.
- (*2) Measured values exceeding 9999 ppm are displayed as ++++.
- (*3) Measurements are displayed in vol% only.
- (*4) For multi-component meters, other components can only be selected from "-P□□".

Table 9 CH₄

Range	Code	Note
None	-NN	—
0-2/20 vol%	-P1	—
0-3/30 vol%	-P2	—
0-5/50 vol%	-P3	—
0-10/100 vol%	-P4	Optional range

Table 10 O₂

Range	Code	Note
None	-NN	—
0-5/25 vol% (*1)	-M1	for built-in paramagnetic O ₂ analyzer
0-25/100 vol% (*2)	-M2	for built-in paramagnetic O ₂ analyzer
0-5/100 vol% (*3)	-R1	For ZR802G and other external O ₂ analyzers

- (*1) Available when the O₂ analyzer is "-3".
- (*2) Available when the O₂ analyzer is "-3" or "-4".
- (*3) Select this option when the O₂ analyzer is "-1" or "-2".

Terminal assignment

TM1			
1	DI1	2	DI7
3		4	
5	DI2	6	DI8
7		8	
9	DI3	10	N. C.
11		12	
13	DI4	14	N. C.
15		16	
17	DI5	18	N. C.
19		20	
21	DI6	22	N. C.
23			

TM2			
(*1)			
1	AI+	2	FG (*2)
3	AI-	4	GND
5	N. C.	6	B-
7	N. C.	8	A+
9	AO1+	10	TERM
11	AO1-	12	N. C.
13	AO2+	14	N. C.
15	AO2-	16	N. C.
17	AO3+	18	N. C.
19	AO3-	20	N. C.
21	AO4+	22	N. C.
23	AO4-		

40 mA Max

- *1: Available when O₂ analyzer is "-1" or "-02"
- *2: Digital communication: Available when "-R".

TM3			
1	DO1	2	DO7
3		4	
5	DO2	6	DO8
7		8	
9	DO3	10	DO9
11		12	
13	DO4	14	DO10
15		16	
17	DO5	18	DO11
19		20	
21	DO6	22	N. C.
23			

TM4			
1	DO12NO	2	DO15NO
3	DO12COM	4	DO15COM
5	DO12NC	6	DO15NC
7	DO13NO	8	DO16NO
9	DO13COM	10	DO16COM
11	DO13NC	12	DO16NC
13	DO14NO	14	DO17NO
15	DO14COM	16	DO17COM
17	DO14NC	18	DO17NC
19	N. C.	20	N. C.
21	N. C.	22	N. C.
23	N. C.		

External Dimensions

IR800G

Unit: mm

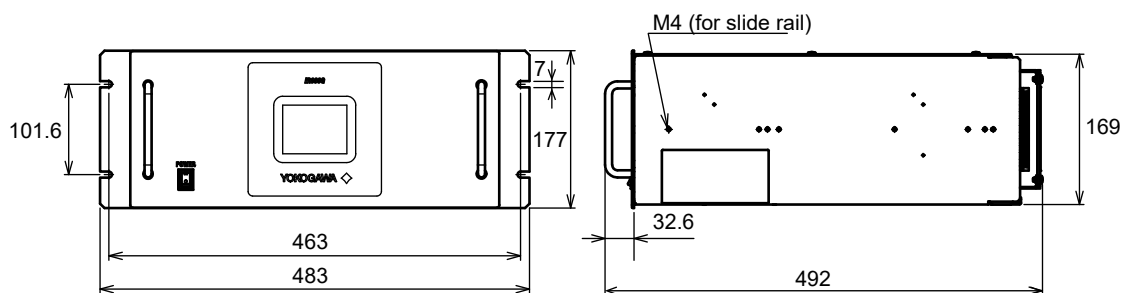

<Rear View>

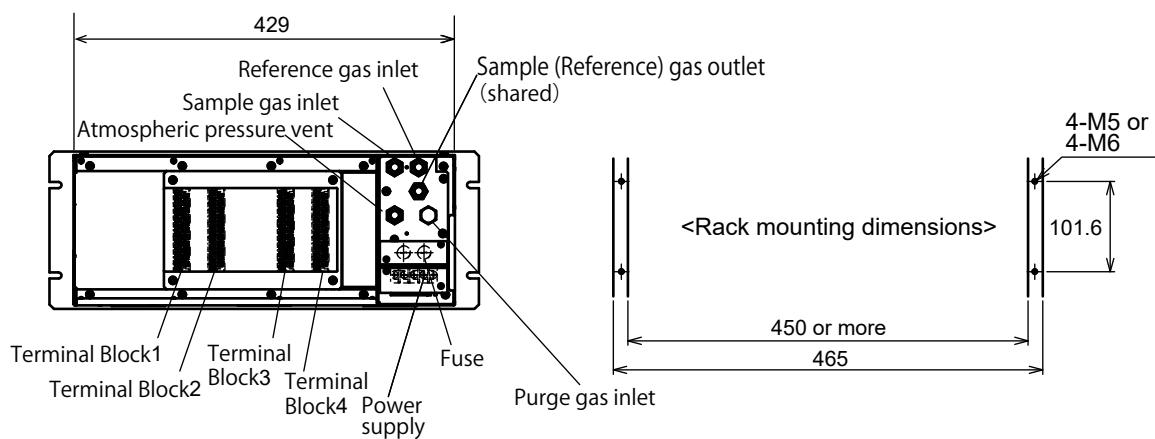

• IR810G

Unit: mm

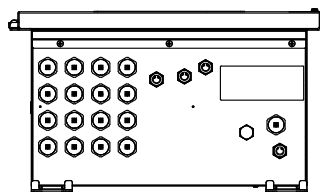
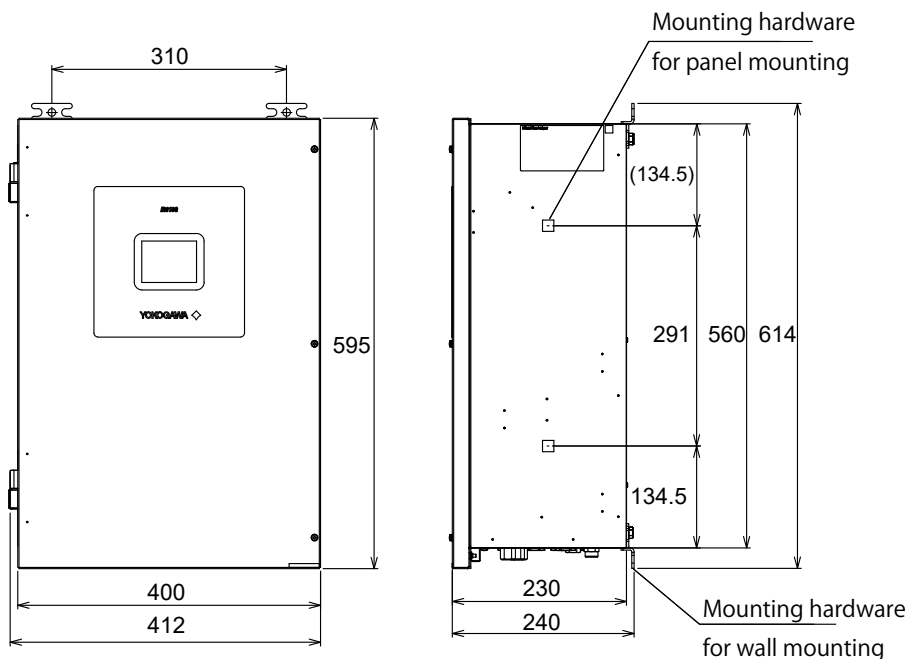

<-W (Wall mount) dimension> 4-M8 or $\phi 10$

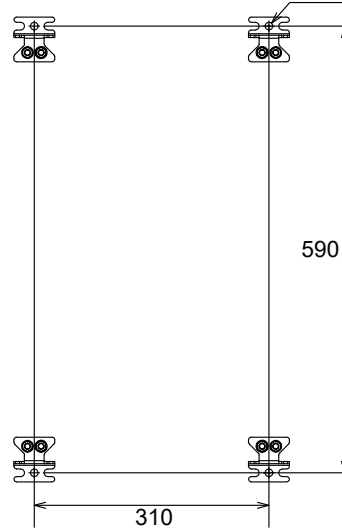

<-P (Panel mount) Panel cut dimension>

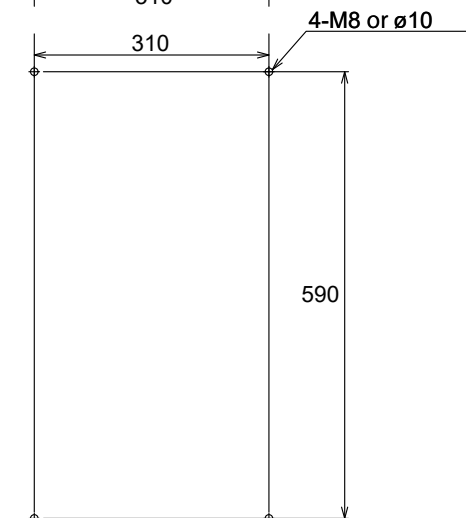
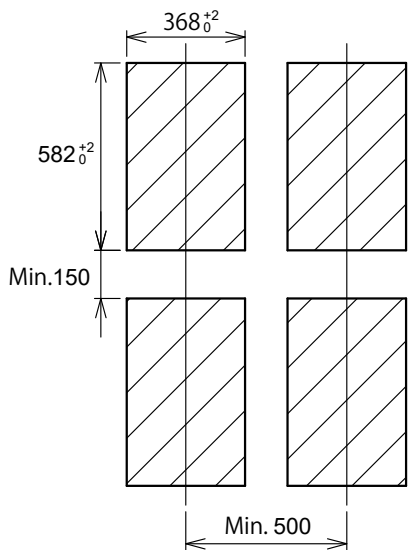

• /RP option

Unit: mm

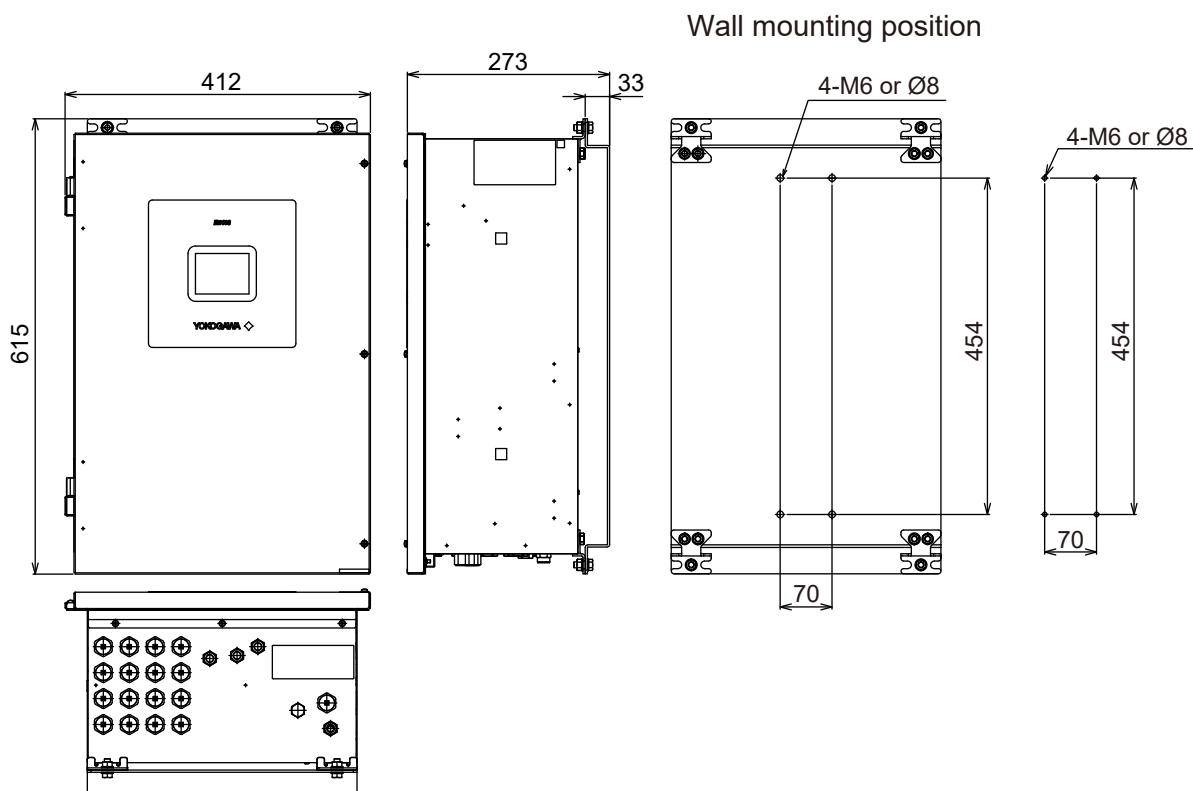

Wall mounting method

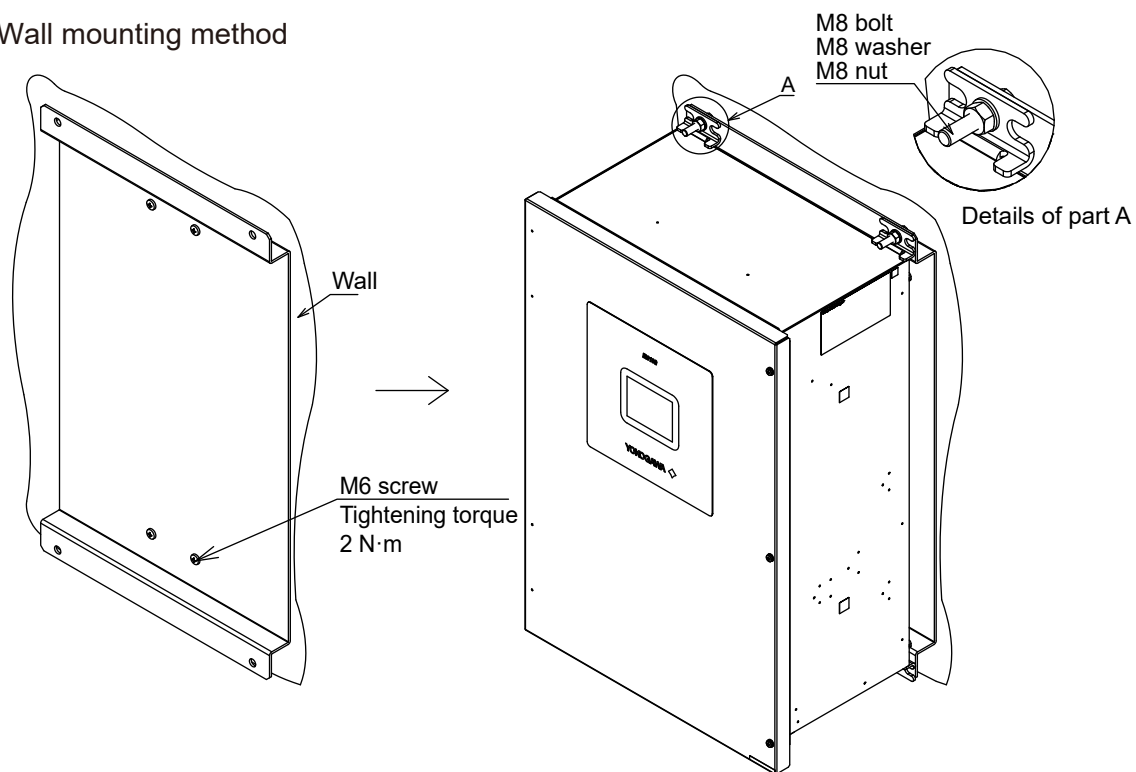

● Accessories

Slide rail

Only included for IR800G Mount type: "-S".

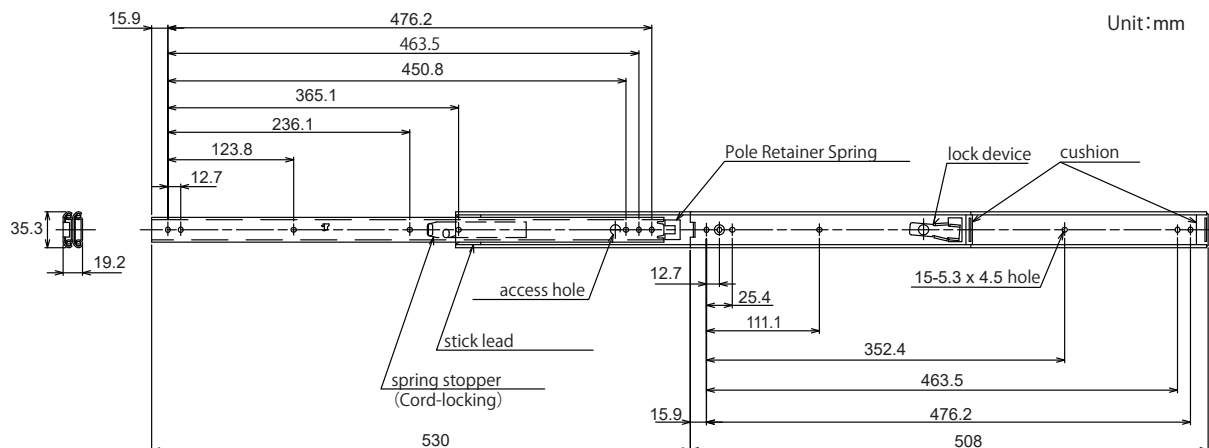

How to install in a 19-inch rack.

The instrument mass should be supported at the bottom of the main unit (or at the side of the main unit when mounting on a slide rail).

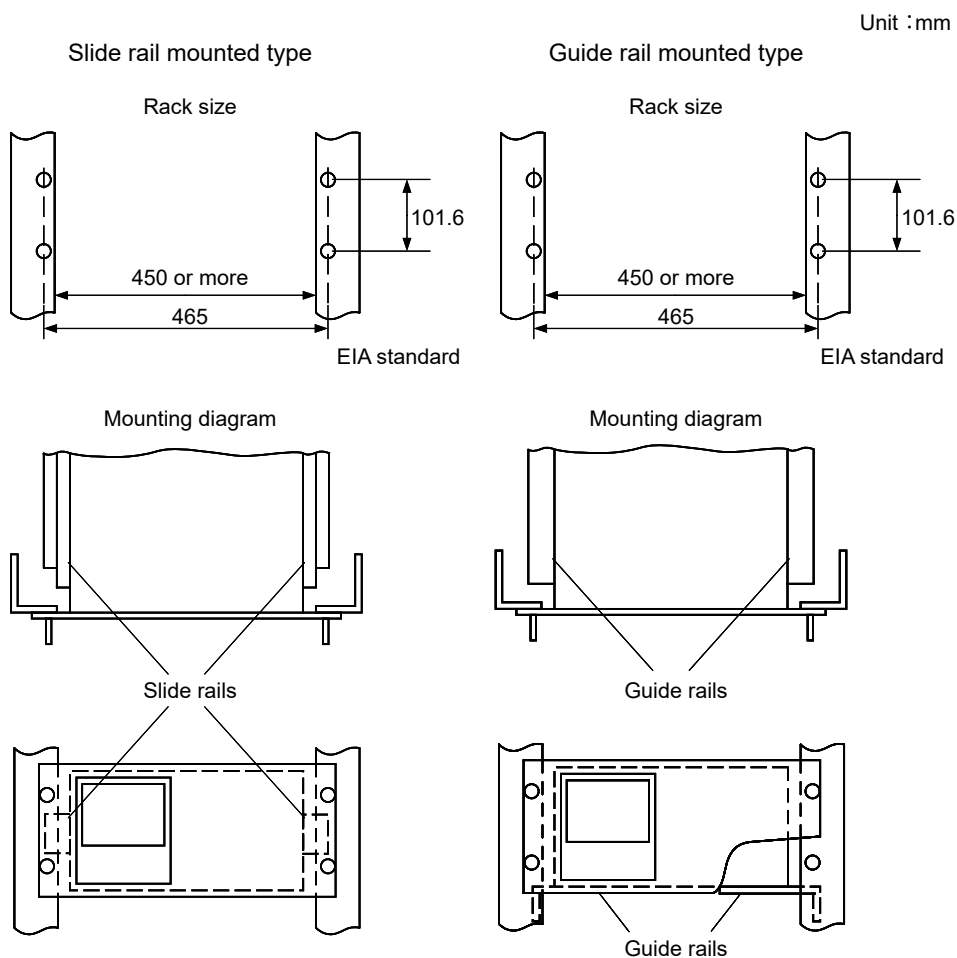

For the guide rail mounted type, a maintenance space (200 mm or more) should be provided on top of the main unit.

Inquiry Sheet for IR800G, IR810G Infrared Gas Analyzer

Place a checkmark ✓ in the appropriate box and fill in the specific information in the blanks for your reference.

1. General Information

Company: _____ Delivery destination: _____
 Responsible person: _____ Section: _____ (Phone No.) _____
 Plant name: _____ Measurement location: _____
 Purpose: Indication reading, Recording, Telemetry Alarm, Control Others

2. Request specification

Type : IR800G (Rack Type) IR810G (Wall and Panel Mount Type)

Measuring components:

	1st	2nd	3rd	4th
<input type="checkbox"/>	NO			
<input type="checkbox"/>	SO ₂			
<input type="checkbox"/>	CO			
<input type="checkbox"/>	CO ₂			
<input type="checkbox"/>	CH ₄			
<input type="checkbox"/>	NO	SO ₂		
<input type="checkbox"/>	NO	CO		
<input type="checkbox"/>	CO	CO ₂		
<input type="checkbox"/>	CO	CH ₄		
<input type="checkbox"/>	CO ₂	CH ₄		
<input type="checkbox"/>	NO	SO ₂	CO	
<input type="checkbox"/>	CO	CO ₂	CH ₄	
<input type="checkbox"/>	NO	SO ₂	CO	CO ₂

Measuring range:

NO _____ ppm mg/m³
 SO₂ _____ ppm vol% mg/m³ g/m³
 CO _____ ppm vol% mg/m³
 CO₂ _____ ppm vol%
 CH₄ _____ vol%
 O₂ _____ %

O₂ Analyzer:

Without O₂ analyzer
 External O₂ analyzer: ZR802G, ZR22G (separate arrangement required)
 External O₂ analyzer: separate arrangement required
 Built-in paramagnetic type O₂ analyzer
 Built-in paramagnetic type O₂ analyzer (when the sample contains more than 100 ppm hydrogen)

Modbus communication (RS-485): Yes No

Automatic validation : Yes No

Gas connection: Rc1/4 1/4NPT

Display language: English Chinese Japanese

Mount type: Rack with slide rail (IR800G) Rack without slide rail (IR800G)
 Panel mount (IR810G) Wall mount (IR810G)

Cable glands for wiring (IR810G only) pcs: 6 10 12 16

Peak alarm: Yes No

O₂ compensation: Yes No

Display of Nitric Oxide: NO NO_x

NO₂/NO Converter: With NO₂/NO converter
 CE not required (K9530LE)
 CE conformity

Without NO₂/NO converter

IR202-B compatible wall mount conversion plate: Yes No

3. Sample gas conditions

- Fuel: Gas, Oil, Coal, Refuse, Other fuel _____
- (1) Temperature: _____ to _____, Normal temperature _____ [°C]
- (2) Pressure: _____ to _____, Normal pressure _____ [MPa]
- (3) Humidity: _____ [vol%]
- (4) Dust: _____ [mg/Nm³]
- (5) Corrosive gas: Yes _____ No

Composition:

Please provide detailed composition information, as it is important to know the influence of interfering gases. In particular, hydrogen and hydrocarbons must be listed since they may affect the measurement.

Contents	Concentration range	
CO	to	<input type="checkbox"/> % <input type="checkbox"/> ppm
CO ₂	to	<input type="checkbox"/> % <input type="checkbox"/> ppm
CH ₄	to	<input type="checkbox"/> % <input type="checkbox"/> ppm
H ₂	to	<input type="checkbox"/> % <input type="checkbox"/> ppm
O ₂	to	<input type="checkbox"/> % <input type="checkbox"/> ppm
N ₂	to	<input type="checkbox"/> % <input type="checkbox"/> ppm
SO ₂	to	<input type="checkbox"/> % <input type="checkbox"/> ppm
NOx	to	<input type="checkbox"/> % <input type="checkbox"/> ppm
H ₂ O	to	<input type="checkbox"/> % <input type="checkbox"/> ppm
	to	<input type="checkbox"/> % <input type="checkbox"/> ppm
	to	<input type="checkbox"/> % <input type="checkbox"/> ppm
	to	<input type="checkbox"/> % <input type="checkbox"/> ppm
	to	<input type="checkbox"/> % <input type="checkbox"/> ppm
	to	<input type="checkbox"/> % <input type="checkbox"/> ppm