

# General Specification

## TC10-L Temperature Controller (Limit Control Type)

GS 05C01E81-11EN

### General

The TC10-L is an FM approved limit controller that can be configured either as a high limit or as a low limit controller by a user. The TC10-L features universal input, 3 Dynamic Colors Led Display two alarm outputs, retransmission output, a timer to count the total time the setpoint is exceeded, and a register to retain the maximum temperature reached. The RS-485 communication interface is available optionally.



### Limit Control Function

(High limit control)

When a measured value (PV) exceeds a setpoint (SP), “EXCEEDED” lamp lights, and “OUT” lamp turns ON (A). The limit output relay is deenergized then. “EXCEEDED” lamp turns off when PV goes into normal condition, while the output (OUT) display lamp stays on as it is (B). The output (OUT) display lamp turns off when a confirming operation is done by an operator (C). The way to confirm is pressing the RST (  ) key (or by DI1, according to the setting of setup parameter DIS). The confirming operation is not accepted during PV exceeds SP (D) (during EXCEEDED lamp lights\*). State of output relay is de-energized whenever “OUT” lamp is on.

\* Check the “HYS” value if the EXCEEDED lamp is not turn off when PV is lower than SP.

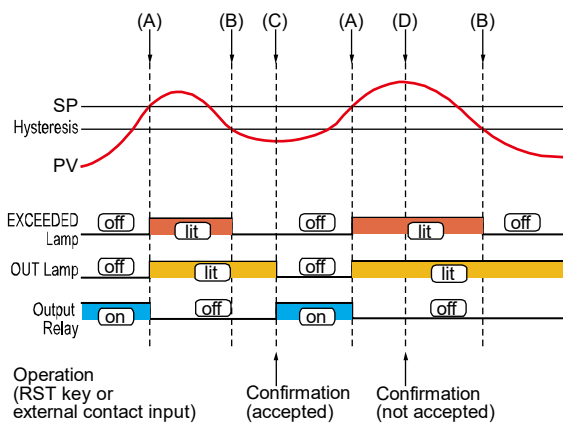

(Low limit control)

When a measured value (PV) exceeds a setpoint (SP), “EXCEEDED” lamp lights, and “OUT” lamp turns ON (A).

The limit output relay is deenergized then.

“EXCEEDED” lamp turns off when PV goes into normal condition, while the output (OUT) display lamp stays on as it is (B). The output (OUT) display lamp turns off when a confirming operation is done by an operator (C). The way to confirm is pressing the RST (  ) key (or by DI1, according to the setting of setup parameter DIS). The confirming operation is not accepted during PV exceeds SP (D) (during EXCEEDED lamp lights\*). State of output relay is de-energized whenever “OUT” lamp is on.

\* Check the “HYS” value if the EXCEEDED lamp is not turn off when PV is higher than SP.

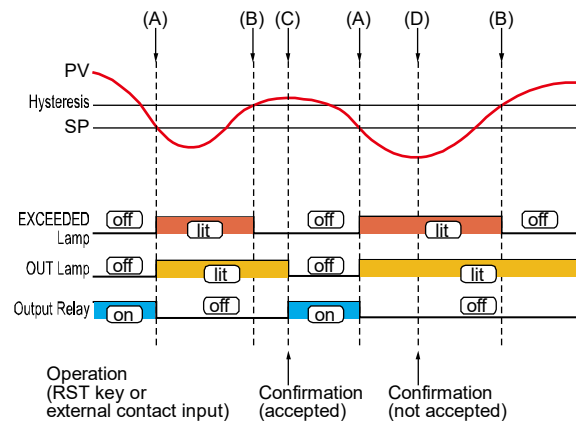

## Hardware Specifications

### Display Specifications

Main display: 4 digits height 15.5 mm, 3 color red, green and amber

Secondary display: 4 digits height 7 mm, green color

Display updating time: 500 ms

### Universal Input Specifications

TC J	-50 to +1000°C	-58 to +1832°F
TC K	-50 to +1370°C	-58 to +2498°F
TC S (°)	-50 to +1760°C	-58 to +3200°F
TC R	-50 to +1760°C	-58 to +3200°F
TC T	-70 to +400°C	-94 to +752°F
TC N	-50 to +1300°C	-58 to +2372°F
Pt100	-200 to +850°C	-328 to +1562°F
Pt1000	-200 to +850°C	-328 to +1562°F

Linear 0 to 60 mV

Linear 12 to 60 mV

Linear 0 to 20 mA (this selection forces Out 4 = TX)

Linear 4 to 20 mA (this selection forces Out 4 = TX)

Linear 0 to 5 V

Linear 1 to 5 V

Linear 0 to 10 V

Linear 2 to 10 V

Sampling time: 130 ms

Resolution: 30000 counts

Total Accuracy:  $\pm 0.5\%$  of F.S.  $\pm 1$  digit

\*:  $\pm 1.0\%$  of F.S.  $\pm 1$  digit

Resistance-temperature detector (RTD) measured current; Pt100: 150  $\mu$ A, Pt1000: 15.5  $\mu$ A

Response time: 2 second or less, 63% (10 - 90%)

(The time required for transmission output to reach 63% of the maximum excursion when PV abruptly changes from 10% to 90%)

### Output Specifications

OUT 1: Analog output: 0/4 to 20 mA, galvanically isolated, RL max. 600 $\Omega$   $\pm 0.2\%$  of F.S. or 0/2 to 10 V, galvanically isolated, RL min.: 500 $\Omega$   $\pm 0.3\%$  F.S.

OUT 2: Relay SPST -NO 2A/250 Vac or voltage to drive SSR 13V max. @1mA, 10.5 min @15mA  $\pm 10\%$

OUT 3: Relay SPST -NO 2A/250 Vac or voltage to drive SSR 13V max. @1mA, 10.5 min @15mA  $\pm 10\%$

OUT 4: programmable: voltage output to drive SSR 13V max. @1mA, 10.5 min. @15mA  $\pm 10\%$ , 12 VDC (20 mA) transmitter power supply or 2nd digital input

### Regulatory Compliance

#### Applicable Standards

EMC Directive:

EN 61326-1 Class A, Table 2 (For use in industrial locations)

EN 55011 Class A, Group 1

(During the test, the instrument continues to operate at the measurement accuracy within specification.)

LV Directive:

EN 61010-1, EN 61010-2-030

UL 61010-1 CSA 61010-1

Certified for FM-3810 and FM-3545.

Installation category: II

Pollution category: 2

EU RoHS Directive: EN IEC 63000

### Power Supply Specification and Isolation Voltage

#### 100 to 240 VAC (-15 to +10% of the nominal value)

Power consumption: 6.0 VA max. (100 to 240 VAC)

#### Isolation Voltage

3000 V AC for 1 minute between primary and secondary terminals

(Primary terminals = Power and relay output terminals, Secondary terminals = Analog I/O signal terminals, contact input terminals, and communication terminals.)

PV (Universal) input terminal	Internal Circuits	Power Supply
DI1, OUT4		
OUT1 (Analog output)		
RS485 (Communication)		
OUT2 (Relay output)		
OUT3 (Relay output)		

———— Reinforced insulation (Isolation Voltage 3000VAC)

----- Functional insulation (Isolation Voltage 50VAC)

### Environmental Conditions

#### Normal Operating Conditions

Operating temperature: 0 to 50°C (32 to 122°F)

Humidity: 20 to 90% RH, not condensing

#### Temperature Effects

Analog input: It is part of the global accuracy

Reference junction compensation:  $\pm 0.1^\circ\text{C}/^\circ\text{C}$  or less

Analog output:  $\pm 0.05\%$  of F.S./ $^\circ\text{C}$  or less

#### Storage temperature

Storage temperature: -20 to +70°C (-4 to +158°F)

Humidity: 20 to 95% RH, not condensing

## External Dimensions and Panel Cutout Dimensions

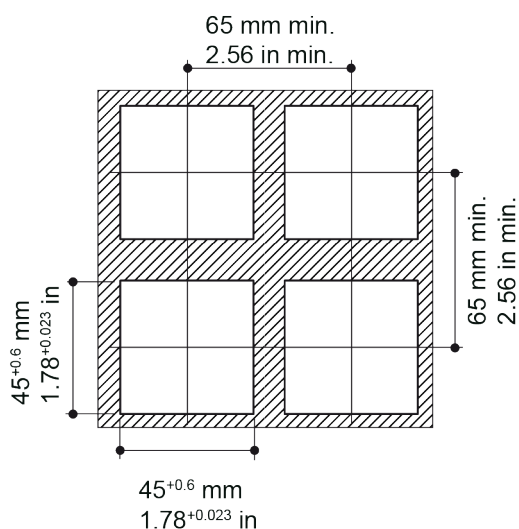
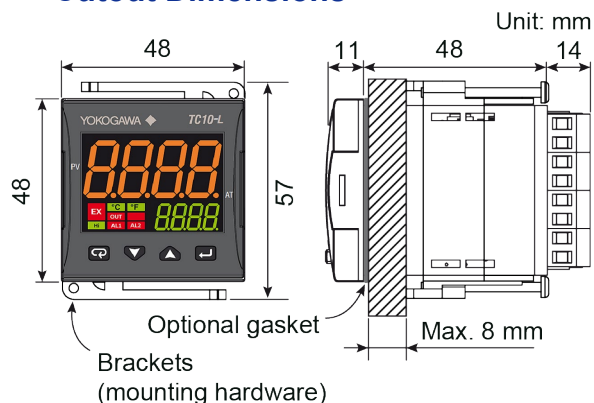

**Dimensions:** 48 x 48, depth 62 mm

(depth from the panel surface)  
(1.89 x 1.89 x 2.87 in.)

**Panel cutout:** 45[-0, +0.6] x 45[-0, +0.6] mm

(1.78[- 0.000, +0.023] x 1.78[- 0.000, +0.023] in.)

**Weight:** 180 g max.

## Terminal Arrangement

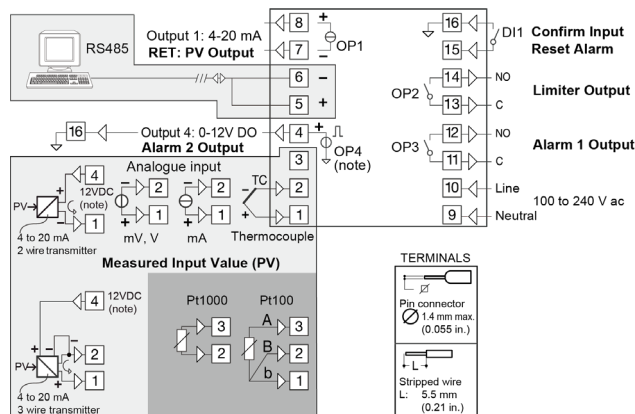

Note: Terminal 4 can be programmed as:

- 0 to 12 V SSR Drive Output (OP4) connecting the load between terminals 4 and 16;
- 12 Vdc (20 mA) transmitter power supply connecting the 2 wire transmitter between terminals 4 and 1;
- for 3 wire transmitter connect terminal 4 to transmitter power supply input and terminal 1 and 2 to transmitter signal output.

## Construction, Mounting, and Wiring

**Case:** Plastic, self-extinguishing degree: V-0 according to UL 94

**Front protection:** IP 65 (when the optional panel gasket is mounted) for indoor locations according to EN 60070-1

**Terminals protection:** IP 20 according to EN 60070-1

**Installation:** Panel mounting

**Terminal block:** 16 screw terminals for cables of 0.25 to 2.5 mm<sup>2</sup> (AWG22 to AWG14) with connection diagram, tightening torque 0.5 Nm;

## Basic Conditions and Individual Contracts at the Time of Purchase

The warranty for this product is defined in the basic conditions and individual contracts at the time of purchase. The individual conditions are as follows.

### ● Warranty period

Unless otherwise agreed in writing, the warranty period of the products shall be twelve (12) months from installation into the final application at the end-user location or eighteen (18) months from the date of manufacture, whichever comes first.

The warranty conditions for the firmware installed in this products are same as that of the hardware.

### ● Handling of non-conforming products

If Yokogawa verifies a non-conformity of the product that is attributable to Yokogawa within the warranty period, we will deliver an equivalent product.

Yokogawa can not provide a free evaluation of non-conforming products.

## ■ Model and Suffix Code

Model Code	Suffix codes									Description
TC10	-L	□	C	□	□	□	D	□	F	Temperature Controller with an universal input, one logic input, and one voltage output for SSR.
Type	-L									Always "-L"
Power supply		H								100 to 240 VAC
Fixed code			C							Always "C"
OUT1-3				A	R	R				Relay outputs for limit control and alarm with PV analog transmission
				A	R	N				Relay output for limit control with PV analog transmission
				N	R	R				Relay outputs for limit control and alarm
				N	R	N				Relay output for limit control
IN/OUT4(Fixed code)						D				Selectable I/O (logic input / 12V SSR drive output / 12VDC 20mA transmitter power supply)
Serial communication								S		RS-485 communication Modbus/RTU
								N		None
Fixed code									F	Always "F"
Fixed code										/GK Panel gasket for IP65 (mandatory for FM)

## ■ Items to be specified when ordering

Model and suffix code.

## ■ Standard accessories

Brackets (mounting hardware), Quick Guide

## ■ Optional accessory

Panel gasket for IP65: A00336

## ■ User's Manual

Product user's manuals can be downloaded or viewed at the following URL.

URL: <http://www.yokogawa.com/ns/tc10/im>